

PRICE LIST
ENGLISH

20
22



Automatic Passion



Download myVDS App

All the VDS experience
from today available
for iOS e Android.

You can consult manuals, tutorial
videos, technical sheets and have
a VDS specialist at your disposal.



VDS AUTOMATION PRICE LIST 2022

Swing Gates	5
Arm automations for Swing Gates	7
Underground automations for Swing Gates	21
Hydraulic automations for Swing Gates	25
Sliding Gates	31
Garage Doors	47
Road Barriers	57
Traffic Bollards	67
Rolling Shutters	73
Shutters and Awings	79
Skylights, Windows, Domes	93
Sliding Doors & Turnstiles	97
Electronic Control Board	111
Control Board	112
Radio Systems	116
Automation Accessories	119
Access Control	120
Safety and Detection	124
Signaling	128
Mechanical	130
Generic	132



AUTOMATIONS FOR
SWING GATES

ARM AUTOMATIONS FOR **SWING GATES**

PM I PM1

LINEAR ELECTROMECHANICAL OPERATOR 230V

i LEAF LENGHT UP TO 3,5 MT



INSTRUCTIONS

RESIDENTIAL

COLLECTIVE

POWER SUPPLY 230V

REVERSIBLE

IRREVERSIBLE

FEATURES

- Sturdy aluminum structure
- Rod stroke MM300-MM400-MM600
- Stainless steel rod with scraper
- Very quiet operation
- Electric motor with electrobrake (PM 1)
- Thermal cut out 140°
- Manual release with customized key
- Lithium grease lubrications of mechanical parts against corrosion, oxidation and rust
- 120° opening
- Quick installation with multi-position brackets and cover for brackets in technopolimers
- Anti-squashing system * (EN 12453)
- Slowing down function * (EN 12453)
- Power supply 230V

* Functions guaranteed with VDS electronics devices

PERFORMANCE REQUIREMENTS

- Operating Cycle SEMI-INTENSIVE
- Use frequency 50%
- Opening time 15-25-30 SEC
- Thrust 1500 N

TECHNICAL FEATURES

Power supply	230VAC
Leaf weight	250 KG
Leaf lenght	3,50 M
Engine RPM	800 RPM
Average absorption	1A
Absorbed power	250 W
Standard limit switch	NO
Condenser	12,5 UF
Motor weight	7,5 KG
Noise level	<30 DBA
Enviromental conditions	-20/+55° C
Protection degree	IP55

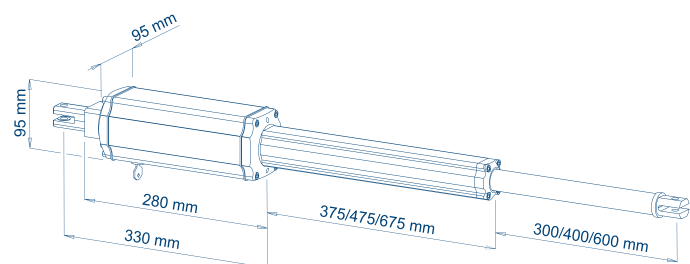

OPERATORS AND ACCESSORIES

CODE	MODEL	DESCRIPTION	PRICE
100053	PM1-300 *	Irreversible - Stroke 300 mm - Leaf length up to 1,80 mt	€ 386,00 ●
100053/1	PM1-400 *	Irreversible - Stroke 400 mm - Leaf length up to 2,50 mt	€ 413,00 ●
100053/13	PM1-600 *	Irreversible - Stroke 600 mm - Leaf length up to 3,50 mt	€ 438,00 ●
100052	PM-300 **	Reversible - Stroke 300 mm - Leaf length up to 1,80 mt	€ 379,00 ●
100052/1	PM-400 **	Reversible - Stroke 400 mm - Leaf length up to 2,50 mt	€ 407,00 ●
100053/14	PM-600 **	Reversible - Stroke 600 mm - Leaf length up to 3,50 mt	€ 425,00 ●
121060	CPS-300	Rod cover - Stroke 300 mm	€ 36,00
111	CPS 400	Rod cover - Stroke 400 mm	€ 41,00
111/1	CPS 600	Rod cover - Stroke 600 mm	€ 67,00
140102	STR	Adjustable rear bracket	€ 37,00

 PZ. PALLET
800x1200x1100 | 30 pz. 280 KG

- * For **PM1** (irreversible) for leaf longer than 1,80 mt is suggested the use of an electric lock
- ** For **PM** (reversible) is always required the use of the electro lock
- For better radio reception we recommend the use of an external aerial code 210/1
- In the presence of strong wind and cold temperatures, the performance of the actuator can be significantly reduced



COLOR SUPPLEMENT	PRICE
Customize your motor by indicating the RAL code on the order	€ 89,00

KIT CONTENT



COD. E105
Control board 230V



COD. 12/C
Pair of photocells



COD. 23/8
LED flashing light



COD. 198/5
Key selector



COD. E010
Remote control



COD. 165B
Warning sign

KIT 2 LEAVES

CODE	MODEL	DESCRIPTION	PRICE
112550	KIT PM1-300 *	Kit 2 leaves for gates up to 3,60 mt	€ 1.175,00 ●
112550/4	KIT PM1-400 *	Kit 2 leaves for gates up to 5 mt	€ 1.225,00 ●
112542/8	KIT PM1-600 *	Kit 2 leaves for gates up to 7 mt	€ 1.277,00 ●
112542	KIT PM-300 **	Kit 2 leaves for gates up to 3,60 mt	€ 1.152,00 ●
112542/4	KIT PM-400 **	Kit 2 leaves for gates up to 5 mt	€ 1.158,00 ●
112542/6	KIT PM-600 **	Kit 2 leaves for gates up to 7 mt	€ 1.252,00 ●

 PZ. PALLET
800x1200x1200 | 15 pz. 270 KG

KIT 1 LEAF

CODE	MODEL	DESCRIPTION	PRICE
112557	KIT PM1-300 *	Kit 1 leaf for gates up to 1,80 mt	€ 788,00 ●
112550/3	KIT PM1-400 *	Kit 1 leaf for gates up to 2,50 mt	€ 813,00 ●
1200041/1	KIT PM1-600 *	Kit 1 leaf for gates up to 3,50 mt	€ 839,00 ●
112556	KIT PM-300 **	Kit 1 leaf for gates up to 1,80 mt	€ 779,00 ●
112556/1	KIT PM-400 **	Kit 1 leaf for gates up to 2,50 mt	€ 798,00 ●
112556/6	KIT PM-600 **	Kit 1 leaf for gates up to 3,50 mt	€ 804,00 ●

EXTRA ACCESSORIES



COD. 140102
Adjustable rear bracket



COD. CPS
Rod cover

PM1-SC

LINEAR ELECTROMECHANICAL OPERATOR 230V - 24V

i LEAF LENGHT UP TO 3 MT



INSTRUCTIONS

RESIDENTIAL

COLLECTIVE

POWER SUPPLY 230V - 24V

IRREVERSIBLE

FEATURES

- Sturdy aluminum structure
- Rod stroke MM 300 - MM 400 - MM 500
- Strong rolled warm shaft
- Standard opening limit switch (optional in closing)
- Very quiet operation
- High Performance electric motor
- Thermal cut out 140°
- Manual release with key
- Lithium grease lubrications of mechanical parts against corrosion, oxidation and rust
- 120° opening
- Quick installation with multi-position brackets and cover for brackets in technopolimers
- Anti-squashing system * (EN 12453)
- Slowing down function * (EN 12453)
- Power supply 230V - 24V
- Optional kit Battery Back-up

* Functions guaranteed with VDS electronics devices

PERFORMANCE REQUIREMENTS

- Operating Cycle SEMI-INTENSIVE 230V, INTENSIVE 24V
- Use frequency 50% (230V) - 90% (24V)
- Opening time 15 - 25 - 30 SEC
- Thrust 1500 N

TECHNICAL FEATURES

	PM1-SC 230V	PM1-SC 24V
Power supply	230VAC	24VCC
Leaf weight	200 KG	200 KG
Leaf length	3 MT	3 MT
Engine RPM	1400 RPM	1500 RPM
Average absorption	1 A	3 A
Absorbed power	200 W	50 W
Standard limit switch	OPENING	OPENING
Condenser	16 UF	-
Motor weight	6,5 KG	6,5 KG
Noise level	< 30 DBA	< 30 DBA
Enviromental conditions	-20 / +55° C	-20 / +55° C
Protection degree	IP55	IP55

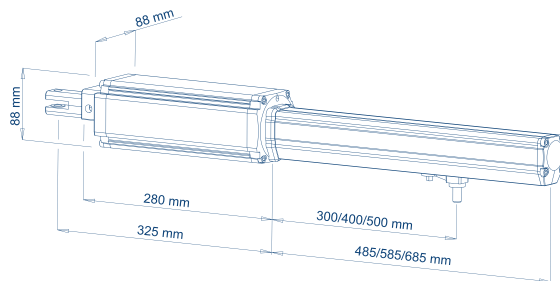

OPERATORS AND ACCESSORIES

CODE	MODEL	DESCRIPTION	PRICE
100038	PM1-SC 300-230V	Irreversible - Stroke 300 mm - Leaf length up to 1,80 mt	€ 322,00
121820	PM1-SC 400-230V *	Irreversible - Stroke 400 mm - Leaf length up to 2,50 mt	€ 348,00
121820/2	PM1-SC 500-230V *	Irreversible - Stroke 500 mm - Leaf length up to 3 mt	€ 396,00
100038/24	PM1-SC 300-24V	Irreversible - Stroke 300 mm - Leaf length up to 1,80 mt	€ 347,00
121841/24	PM1-SC 400-24V *	Irreversible - Stroke 400 mm - Leaf length up to 2,50 mt	€ 370,00
121822/24	PM1-SC 500-24V *	Irreversible - Stroke 500 mm - Leaf length up to 3 mt	€ 395,00
140102	STR	Adjustable rear bracket	€ 37,00

 PZ. PALLET
800x1200x1200 | 30 pz. 270 KG

- * For **PM1-SC** for leaf longer than 1,80 mt is suggested the use of an electric lock
- For better radio reception we recommend the use of an external aerial code 210/1
- In the presence of strong wind and cold temperatures, the performance of the actuator can be significantly reduced



COLOR SUPPLEMENT **PRICE**

Customize your motor by indicating the RAL code on the order

€ 89,00

KIT CONTENT

The kit contains **1 control board** + accessories



COD. E105
Control board 230V



COD. F103
Control board 24V



COD. 12/C
Pair of photocells



COD. 23/8
LED flashing light



COD. 198/5
Key selector



COD. E010
Remote control



COD. 165B
Warning sign

KIT 2 LEAVES

CODE	MODEL	DESCRIPTION	PRICE
112537/2	KIT PM1-SC 300 230V	Kit 2 leaves for gates up to 3,60 mt	€ 1.044,00
112565	KIT PM1-SC 400 230V *	Kit 2 leaves for gates up to 5 mt	€ 1.092,00
121820/4	KIT PM1-SC 500 230V *	Kit 2 leaves for gates up to 6 mt	€ 1.189,00
112537/24	KIT PM1-SC 300 24V	Kit 2 leaves for gates up to 3,60 mt	€ 1.164,00
112735/24	KIT PM1-SC 400 24V *	Kit 2 leaves for gates up to 5 mt	€ 1.212,00
121822/5	KIT PM1-SC 500 24V *	Kit 2 leaves for gates up to 6 mt	€ 1.315,00

 PZ. PALLET
800x1200x1200 | 15 pz. 250 KG

KIT 1 LEAF

CODE	MODEL	DESCRIPTION	PRICE
110537/1	KIT PM1-SC 300 230V	Kit 1 leaf for gates up to 1,80 mt	€ 722,00
11256	KIT PM1-SC 400 230V *	Kit 1 leaf for gates up to 2,50 mt	€ 746,00
121820/5	KIT PM1-SC 500 230V *	Kit 1 leaf for gates up to 3 mt	€ 795,00
110537/2	KIT PM1-SC 300 24V	Kit 1 leaf for gates up to 1,80 mt	€ 819,00
110537/4	KIT PM1-SC 400 24V *	Kit 1 leaf for gates up to 2,50 mt	€ 843,00
110537/3	KIT PM1-SC 500 24V *	Kit 1 leaf for gates up to 3 mt	€ 920,00

EXTRA ACCESSORIES

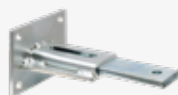

COD. 140102
Adjustable rear bracket

EGO

LINEAR ELECTROMECHANICAL OPERATOR 230V - 24V

i LEAF LENGHT UP TO 3 MT



INSTRUCTIONS

RESIDENTIAL

COLLECTIVE

POWER SUPPLY 230V - 24V

IRREVERSIBLE

FEATURES

- Sturdy aluminum structure
- Rod stroke MM 400 - MM 500
- Stainless steel rod
- Optional limit switch
- Very quiet operation
- High Performance electric motor
- Thermal cut out 140°
- Manual release with key
- Lithium grease lubrications of mechanical parts against corrosion, oxidation and rust
- 120° opening
- Quick installation with multi-position brackets and cover for brackets in technopolimers
- Anti-squashing system * (EN 12453)
- Slowing down function * (EN 12453)
- Power supply 230V - 24V
- Optional kit Battery Back-up

* Functions guaranteed with VDS electronics devices

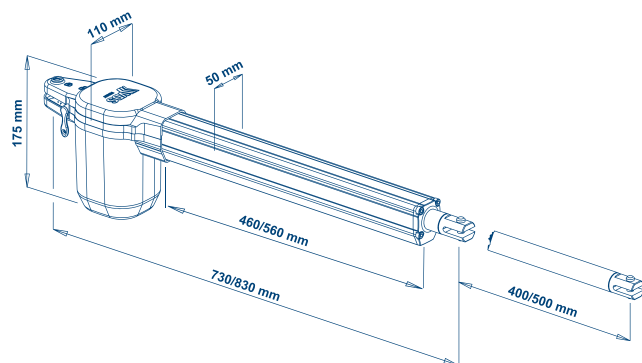

PERFORMANCE REQUIREMENTS

- Operating Cycle SEMI-INTENSIVE 230V, INTENSIVE 24V
- Use frequency 50% (230VAC) - 90% (24VCC)
- Opening time 20 - 25 SEC
- Thrust 2000 N

TECHNICAL FEATURES

	EGO 230	EGO 24
Power supply	230VAC	24VCC
Leaf weight	200 KG	200 KG
Leaf lenght	3 MT	3 MT
Engine RPM	1400 RPM	2800 RPM
Average absorption	1 A	3 A
Absorbed power	200 W	50 W
Standard limit switch	OPTIONAL	OPTIONAL
Condenser	10 UF	-
Motor weight	6,5 KG	6,5 KG
Noise level	< 30 DBA	< 30 DBA
Enviromental conditions	-20 / +55° C	-20 / +55° C
Protection degree	IP55	IP55

OPERATORS AND ACCESSORIES

CODE	MODEL	DESCRIPTION	PRICE
11020	EGO 400 230V *	Irreversible - Stroke 400 mm - Leaf length up to 2,50 mt	€ 362,00
11021	EGO 500 230V *	Irreversible - Stroke 500 mm - Leaf length up to 3 mt	€ 409,00
11020/24	EGO 400 24V *	Irreversible - Stroke 400 mm - Leaf length up to 2,50 mt	€ 384,00
11021/24	EGO 500 24V *	Irreversible - Stroke 500 mm - Leaf length up to 3 mt	€ 417,00
FC012	FC-MECC	Pair of opening - closing mechanical limit switches	€ 46,00
140102	STR	Adjustable rear bracket	€ 37,00

 PZ. PALLET
800x1200x1100 | 30 pz. 270 KG

- * For EGO for leaf longer than 1,80 mt is suggested the use of an electric lock
- For better radio reception we recommend the use of an external antenna code 210/1
- In the presence of strong wind and cold temperatures, the performance of the actuator can be significantly reduced



COLOR SUPPLEMENT	PRICE
Customize your motor by indicating the RAL code on the order	€ 89,00

KIT CONTENT

The kit contains **1 control board** + accessories



COD. E105
Control board 230V



COD. F103
Control board 24V



COD. 12/C
Pair of photocells



COD. 23/8
LED flashing light



COD. 198/5
Key selector



COD. E010
Remote control



COD. 165B
Warning sign

KIT 2 LEAVES

CODE	MODEL	DESCRIPTION	PRICE
11020/2	KIT EGO 400 230V *	Kit 2 leaves for gates up to 5 mt	€ 1.122,00
11021/2	KIT EGO 500 230V *	Kit 2 leaves for gates up to 6 mt	€ 1.220,00
11024/2	KIT EGO 400 24V *	Kit 2 leaves for gates up to 5 mt	€ 1.242,00
11024/4	KIT EGO 500 24V *	Kit 2 leaves for gates up to 6 mt	€ 1.340,00

 PZ. PALLET
800x1200x1200 | 15 pz. 250 KG

KIT 1 LEAF

CODE	MODEL	DESCRIPTION	PRICE
11020/1	KIT EGO 400 230V *	Kit 1 leaf for gates up to 2,5 mt	€ 762,00
11021/1	KIT EGO 500 230V *	Kit 1 leaf for gates up to 3 mt	€ 811,00
11024/1	KIT EGO 400 24V *	Kit 1 leaf for gates up to 2,5 mt	€ 859,00
11024/3	KIT EGO 500 24V *	Kit 1 leaf for gates up to 3 mt	€ 934,00

EXTRA ACCESSORIES

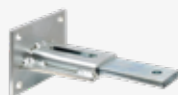

COD. 140102
Adjustable rear bracket



COD. FC012
Pair of mechanical limit switches

LINEAR 11

LINEAR ELECTROMECHANICAL OPERATOR 230V - 24V

i LEAF LENGHT UP TO 3 MT



INSTRUCTIONS

RESIDENTIAL

COLLECTIVE

POWER SUPPLY 230V - 24V

IRREVERSIBLE

FEATURES

- Sturdy aluminum structure
- Rod stroke MM 400 - MM 500
- Stainless steel rod
- Optional limit switch
- Very quiet operation
- High Performance electric motor
- Thermal cut out 140°
- Manual release with key
- Lithium grease lubrications of mechanical parts against corrosion, oxidation and rust
- 120° opening
- Quick installation with multi-position brackets and cover for brackets in technopolimers
- Anti-squashing system * (EN 12453)
- Slowing down function * (EN 12453)
- Power supply 230V - 24V
- Optional kit Battery Back-up

* Functions guaranteed with VDS electronics devices

PERFORMANCE REQUIREMENTS

- Operating Cycle SEMI-INTENSIVE 230V, INTENSIVE 24V
- Use frequency 50% (230VAC) - 90% (24VCC)
- Opening time 20 - 25 SEC
- Thrust 2000 N

TECHNICAL FEATURES

	LINEAR 11 230	LINEAR 11 24
Power supply	230VAC	24VCC
Leaf weight	200 KG	200 KG
Leaf lenght	3 MT	3 MT
Engine RPM	1400 RPM	1500 RPM
Average absorption	1 A	3 A
Absorbed power	200 W	50 W
Standard limit switch	OPTIONAL	OPTIONAL
Condenser	16 UF	-
Motor weight	6,5 KG	6,5 KG
Noise level	< 30 DBA	< 30 DBA
Enviromental conditions	-20 / +55° C	-20 / +55° C
Protection degree	IP55	IP55

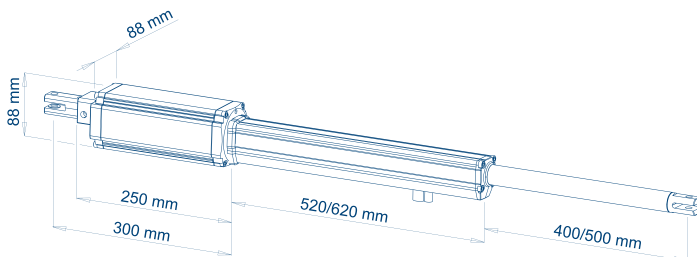

OPERATORS AND ACCESSORIES

CODE	MODEL	DESCRIPTION	PRICE
100018	LINEAR 11 400 230V *	Irreversible - Stroke 400 mm - Leaf length up to 2,50 mt	€ 370,00 ●
100018/5	LINEAR 11 500 230V *	Irreversible - Stroke 500 mm - Leaf length up to 3 mt	€ 396,00 ●
100018/24	LINEAR 11 400 24V *	Irreversible - Stroke 400 mm - Leaf length up to 2,50 mt	€ 383,00 ●
100018/7	LINEAR 11 500 24V *	Irreversible - Stroke 500 mm - Leaf length up to 3 mt	€ 408,00 ●
140102	STR	Adjustable rear bracket	€ 37,00



PZ. PALLET

- * For **LINEAR 11** for leaf longer than 1,80 mt is suggested the use of an electric lock
- For better radio reception we recommend the use of an external aerial code 210/1
- In the presence of strong wind and cold temperatures, the performance of the actuator can be significantly reduce



COLOR SUPPLEMENT	PRICE
Customize your motor by indicating the RAL code on the order	€ 89,00

KIT CONTENT

The kit contains **1 control board** + accessories



COD. E105
Control board 230V



COD. F103
Control board 24V



COD. 12/C
Pair of photocells



COD. 23/8
LED flashing light



COD. 198/5
Key selector



COD. E010
Remote control



COD. 165B
Warning sign

KIT 2 LEAVES

CODE	MODEL	DESCRIPTION	PRICE
100018/1	KIT LINEAR 11 400 230V *	Kit 2 leaves for gates up to 5 mt	€ 1.141,00 ●
100018/4	KIT LINEAR 11 500 230V *	Kit 2 leaves for gates up to 6 mt	€ 1.191,00 ●
100018/2	KIT LINEAR 11 400 24V *	Kit 2 leaves for gates up to 5 mt	€ 1.238,00 ●
100019	KIT LINEAR 11 500 24V *	Kit 2 leaves for gates up to 6 mt	€ 1.288,00 ●

KIT 1 LEAF

CODE	MODEL	DESCRIZIONE	PRICE
10018/1	KIT LINEAR 11 400 230V *	Kit 1 leaf for gates up to 2,50 mt	€ 770,00 ●
10018/4	KIT LINEAR 11 500 230V *	Kit 1 leaf for gates up to 3 mt	€ 796,00 ●
10018/2	KIT LINEAR 11 400 24V *	Kit 1 leaf for gates up to 2,50 mt	€ 854,00 ●
10018/3	KIT LINEAR 11 500 24V *	Kit 1 leaf for gates up to 3 mt	€ 881,00 ●

PZ. PALLET
800x1200x1200 | 15 pz. 250 KG

EXTRA ACCESSORIES

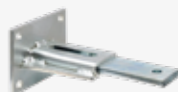

COD. 140102
Adjustable rear bracket

IBIS

ARTICULATED ELECTROMECHANICAL OPERATOR 230V - 24V

i LEAF LENGHT UP TO 2,5 MT



INSTRUCTIONS

 RESIDENTIAL

 COLLECTIVE

 POWER SUPPLY 230V - 24V

 IRREVERSIBLE

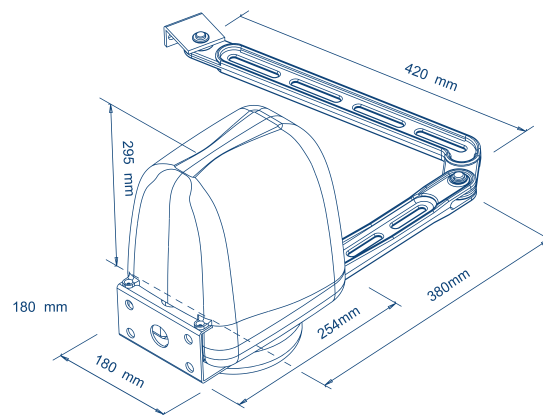

FEATURES

- Sturdy aluminum, die-casting structure
- Steel and cast gears obtained from solid
- Aluminum articulated anti-shaering arm, powder coated
- Very quiet operation
- High Performance electric motor
- Manual release with custom key
- Predisposition for remote release by cable
- Mechanical limit switch in opening and closing
- Lithium grease lubrications of mechanical parts against corrosion, oxidation and rust
- Opening 120°
- Suited for installation on large pillars
- Single version for right and left door
- Control board with obstacle detection
- Anti-squashing system * (EN 12453)
- Slowing down function * (EN 12453)
- Soft start - Soft stop
- Optional kit Battery Back-up
- Power supply 230V - 24V

* Functions guaranteed with VDS electronics devices

PERFORMANCE REQUIREMENTS

- Operating Cycle SEMI-INTENSIVE 230V, INTENSIVE 24V
- Use frequency 50% (230 VAC) - 90% (24 VCC)
- Opening and closing time 15 SEC
- Thrust 250 NM

TECHNICAL FEATURES

	IBIS 230	IBIS 24
Power supply	230VAC	24VAC
Leaf weight	200 KG	150 KG
Leaf length	2,5 MT	2,5 MT
Engine RPM	1400 RPM	1800 RPM
Average absorption	1 A	3 A
Absorbed power	250 W	50 W
Condenser	8 UF	-
Motor weight	9,5 KG	9,5 KG
Noise level	< 30 DBA	< 30 DBA
Enviromental conditions	-20 / +55° C	-20 / +55° C
Protection degree	IP44	IP44

LED COURTESY LIGHT

OPERATORS AND ACCESSORIES

CODE	MODEL	DESCRIPTION	PRICE
11281	IBIS 230V *	Irreversible - Leaf lenght up to 2,5 mt	€ 445,00
11280	IBIS 24V *	Irreversible - Leaf lenght up to 2,5 mt	€ 461,00
11280/1	IBIS 24V MASTER *	Irreversible - Leaf lenght up to 2,5 mt Control board and built-in receiver 433 mHz	€ 747,00
K028	SLT	Slide lever	€ 184,00
855	SBL	Maya external release with 3 m cable	€ 107,00
FC011	IBIS-FC	Pair of electric limit switches	€ 52,00



PZ. PALLET
800x1200x1000 | 24 pz. 250 KG

- * For **IBIS** for leaf longer than 2 mt is suggested the use of an electric lock
- For better radio reception we recommend the use of an external aerial code 210/1
- In the presence of strong wind and cold temperatures, the performance of the actuator can be significantly reduced

KIT CONTENT

The kit contains **1 control board** + accessories



COD. E105
Control board 230V



COD. F103
Control board 24V



COD. 12/C
Pair of photocells



COD. 23/8
LED flashing light



COD. 198/5
Key selector



COD. E010
Remote control



COD. 165B
Warning sign

KIT 2 LEAVES

CODE	MODEL	DESCRIPTION	PRICE
11281/2	KIT IBIS 230V *	Kit 2 leaves for gates up to 5 mt	€ 1.283,00
11280/2	KIT IBIS 24V *	Kit 2 leaves for gates up to 5 mt	€ 1.355,00

KIT 1 LEAF

CODE	MODEL	DESCRIPTION	PRICE
11281/3	KIT IBIS 230V *	Kit 1 leaf for gates up to 2,5 mt	€ 839,00
11280/3	KIT IBIS 24V *	Kit 1 leaf for gates up to 2,5 mt	€ 895,00



PZ. PALLET
800x1200x1200 | 10 pz. 270 KG

EXTRA ACCESSORIES



COD. K028
Slide lever



COD. 855
Maya external release
with 3 m cable



COD. FC011
Pair of electric limit
switches

TEKNO

ARTICULATED ELECTROMECHANICAL OPERATOR 230V

i LEAF LENGHT UP TO 3,5 MT



INSTRUCTIONS



RESIDENTIAL



COLLECTIVE



POWER SUPPLY 230V



IRREVERSIBLE

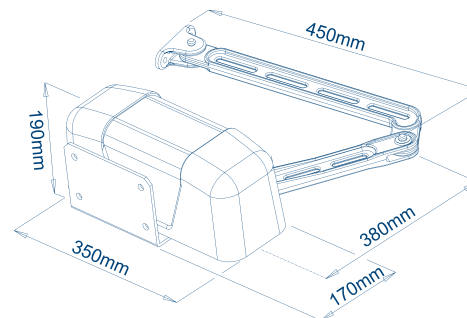

FEATURES

- Sturdy aluminum, die-casting structure
- Steel and cast gears obtained from solid
- Aluminum articulated anti-shaering arm, powder coated
- Very quiet operation
- High Performance electric motor
- Mechanical release with triangular key
- Electric limit switch in opening and closing
- Lithium grease lubrications of mechanical parts
- against
- corrosion, oxidation and rust
- Opening 120°
- Suited for installation on large pillars
- Single version for right and left door
- Control panel with obstacle detection
- Anti-squashing system * (EN 12453)
- Slowing down function * (EN 12453)
- Power supply 230V

* Functions guaranteed with VDS electronics devices

PERFORMANCE REQUIREMENTS

- Operating Cycle **SEMI-INTENSIVE**
- Use frequency 50% (230VAC)
- Opening and closing time 15 SEC
- Thrust 250 NM

TECHNICAL FEATURES

Power supply	230VAC
Leaf weight	800 KG
Leaf lenght	3,5 MT
Engine RPM	1400 RPM
Average absorption	1,3 A
Absorbed power	250 W
Standard limit switch	ELETTRICO
Condenser	12,5 UF
Motor weight	8 KG
Noise level	< 30 DBA
Enviromental conditions	-20 / +55° C
Protection degree	IP44

OPERATOR

CODE	MODEL	DESCRIPTION	PRICE
100055	TEKNO 230V *	Irreversible - Leaf lenght up to 3,5 mt	€ 555,00

 PZ. PALLET
800x1200x1000 | 24 pz. 250 KG

- * For **TEKNO** for leaf longer than 2 mt is suggested the use of an electric lock
- For better radio reception we recommend the use of an external aerial code 210/1
- In the presence of strong wind and cold temperatures, the performance of the actuator can be significantly reduced



COLOR SUPPLEMENT	PRICE
Customize your motor by indicating the RAL code on the order	€ 89,00

KIT CONTENT



COD. E105
Control board 230V



COD. 12/C
Pair of photocells



COD. 23/8
LED flashing light



COD. 198/5
Key selector



COD. E010
Remote control



COD. 165B
Warning sign

KIT 2 LEAVES

CODE	MODEL	DESCRIPTION	PRICE
10055/2	KIT TEKNO 230V *	Kit 2 leaves for gates up to 7 mt	€ 1.517,00

KIT 1 LEAF

CODE	MODEL	DESCRIPTION	PRICE
10055/1	KIT TEKNO 230V *	Kit 1 leaf for gates up to 3,5 mt	€ 962,00

 PZ. PALLET
10 pz. 300 KG

UNDERGROUND AUTOMATIONS
FOR **SWING GATES**

UNDER-V

UNDERGROUND ELECTROMECHANICAL OPERATOR 230V - 24V

i LEAF LENGHT UP TO 2,5 MT



INSTRUCTIONS

RESIDENTIAL

COLLECTIVE

POWER SUPPLY 230V - 24V

IRREVERSIBLE



FEATURES

- Sturdy aluminum, die-casting structure
- Steel and cast gears obtained from solid
- Self-supporting operator, ideal for large gates
- Kit levers 90° opening
- Galvanized steel foundation box
- Very quiet operation
- High Performance electric motor
- Mechanical release for emergency operation with lever supplied
- Shaft drive and scrow in stainless steel
- Lithium grease lubrications of mechanical parts against corrosion, oxidation and rust
- 90° opening
- Anti-squashing system * (EN 12453)
- Slowing down function * (EN 12453)
- Optional kit battery back-up
- Power supply 230V - 24V

* Functions guaranteed with VDS electronics devices

PERFORMANCE REQUIREMENTS

- Operating Cycle SEMI-INTENSIVE 230VAC, INTENSIVE 24VCC
- Use frequency 50% (230VAC) - 90% (24VCC)
- Opening time 16 SEC
- Torque 250 Nm
- Pinion rotation 90°

TECHNICAL FEATURES

	UNDER-V 230	UNDER-V 24
Power supply	230VAC	24VCC
Leaf weight	500 KG	500 KG
Leaf lenght	2,5 MT	2,5 MT
Engine RPM	1400	1800
Average absorption	1,4 A	3 A
Absorbed power	280 W	50 W
Condenser	12,5 UF	-
Motor weight	10 KG	10 KG
Noise level	< 30 DBA	< 30 DBA
Enviromental conditions	-20 / +55° C	-20 / +55° C
Protection degree	IP67	IP67

Available with FOUNDATION BOX in galvanized steel and technopolymer with high resistance to corrosion. Predisposition for water drainage pump application.

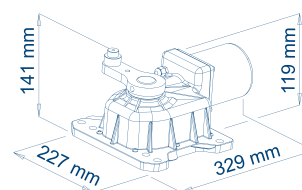
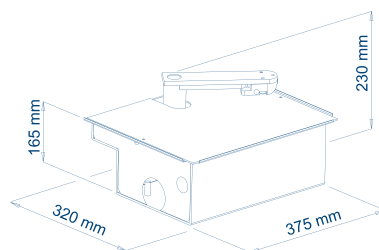

OPERATORS AND ACCESSORIES

CODE	MODEL	DESCRIPTION	PRICE
121991/1	UNDER-V 230V	Irreversible - Leaf lenght up to 2,50 mt	€ 557,00 ●
121991/24	UNDER-V 24V	Irreversible - Leaf lenght up to 2,50 mt	€ 592,00 ●
121992/3	CASSA-Z	Galvanized foundation box complete with levers	€ 309,00
121993/1	CASSA-I	Foundation box in stainless steel complete with levers	€ 681,00
121992/4	CASSA-PZ	Foundation box in technopolymer, galvanized cover	€ 287,00
121992/5	CASSA-PI	Foundation box in technopolymer, stainless steel cover	€ 401,00
FC006	FINE CORSA	Limit switches	€ 52,00
121992/1	180°	180 ° opening kit	€ 229,00
ST9091	COMP	Adapter curved bracket for compatibility with boxes of other brands	€ 75,00
K031	SR	Bracket with lock with custom key	€ 264,00



PZ. PALLET
800x1200x1000 | 32 pz. 490 KG

- For **UNDER-V** for better radio reception we recommend the use of an external aerial code 210/1
- In the presence of strong wind and cold temperatures, the performance of the actuator can be significantly reduced

KIT CONTENT

The kit contains **1 control board** + accessories



COD. E105
Control board 230V



COD. F103
Control board 24V



COD. 12/C
Pair of photocells



COD. 23/8
LED flashing light



COD. 198/5
Key selector



COD. E010
Remote control



COD. 165B
Warning sign

KIT 2 LEAVES

CODE	MODEL	DESCRIPTION	PRICE
121994/1	KIT UNDER-V 230V	Kit 2 leaves for gates up to 5 mt with galvanized boxes	€ 2.212,00 ●
121994/2	KIT UNDER-V 24V	Kit 2 leaves for gates up to 5 mt with galvanized boxes	€ 2.287,00 ●
121994/3	KIT UNDER-V 230V	Kit 2 leaves for gates up to 5 mt without boxes	€ 1.594,00 ●
121994/5	KIT UNDER-V 24V	Kit 2 leaves for gates up to 5 mt without boxes	€ 1.668,00 ●

KIT 1 LEAF

CODE	MODEL	DESCRIPTION	PRICE
121994/4	KIT UNDER-V 230V	Kit 1 leaf for gates up to 2,5 mt with galvanized boxes	€ 1.341,00 ●
121994/6	KIT UNDER-V 24V	Kit 1 leaf for gates up to 2,5 mt with galvanized boxes	€ 1.381,00 ●



PZ. PALLET
800x1200x1200 | 10 pz. 270 KG

EXTRA ACCESSORIES



COD. 121992/1
180° opening kit



COD. K031
Bracket with lock with custom key



COD. ST9091
Adapter curved bracket for compatibility with other brands



COD. 121992/5
Foundation box in technopolymer, stainless cover



COD. 121992/3
Galvanized foundation box complete with levers



COD. 121993/1
Foundation box in stainless steel complete with levers

HYDRAULIC AUTOMATIONS FOR **SWING GATES**

PH | PH1

LINEAR HYDRAULIC OPERATOR 230V

i PH1 IRREVERSIBLE: LEAF LENGTH UP TO 5 MT
PH REVERSIBLE: LEAF LENGTH UP TO 6 MT



INSTRUCTIONS

RESIDENTIAL

COLLECTIVE

POWER SUPPLY 230V

REVERSIBLE

IRREVERSIBLE

FEATURES

- Sturdy aluminum structure
- Stroke MM 270 - MM 390
- Chromed steel rod with uniball ball joint
- Very quiet operation
- Electric motor in oil bath
- 140° thermal protection
- Manual release with key
- 90° opening
- Quick installation with multi-position brackets
- Hydraulic slowdown adjustment in closing
- Power supply 230V
- PH needs electric lock
- No limit switches

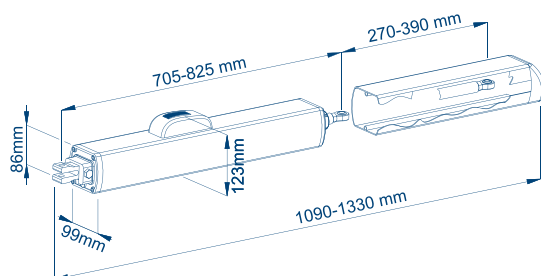

PERFORMANCE REQUIREMENTS

- Operating Cycle INTENSIVE
- Use frequency 90%
- Thrust 1850/2240 N

TECHNICAL FEATURES

	PH1 270	PH 270	PH 390	PH1 390
Power supply	230VAC	230VAC	230VAC	230VAC
Leaf weight	500 KG	500 KG	500 KG	500 KG
Leaf length	1,80 MT	3 MT	6 MT	5 MT
Engine RPM	1400 RPM	1400 RPM	1400 RPM	1400 RPM
Average absorption	1 A	1 A	1,9 A	1,9 A
Absorbed power	250 W	250 W	350 W	350 W
Standard limit switch	NO	NO	NO	NO
Condenser	10 UF	10 UF	10 UF	10 UF
Motor weight	9 KG	9 KG	10 KG	10 KG
Noise level	< 30 DBA	< 30 DBA	< 30 DBA	< 30 DBA
Environmental conditions	-25 / +70° C	-25 / +70° C	-25 / +70° C	-25 / +70° C
Protection degree	IP55	IP55	IP55	IP55

OPERATORS

CODE	MODEL	DESCRIPTION	PRICE	
121913	PH1 270	Irreversible - Stroke 270 mm - Leaf lenght up to 1,80 mt	€ 701,00	●
121927	PH 270 *	Reversible - Stroke 270 mm - Leaf lenght up to 3 mt	€ 701,00	●
12384	PH1 390	Irreversible - Stroke 390 mm - Leaf lenght up to 5 mt	€ 745,00	●
12384/1	PH 390 *	Reversible - Stroke 390 mm - Leaf lenght up to 6 mt	€ 745,00	●



PZ. PALLET
800x1200x1100 | 36 pz. 460 KG

- * For **PH** for leaf is always required the use of an electric lock
- For better radio reception we recommend the use of an external aerial code 210/1
- In the presence of strong wind and cold temperatures, the performance of the actuator can be significantly reduced

KIT CONTENT



COD. E105
Control board 230V



COD. 12/C
Pair of photocells



COD. 23/8
LED flashing light



COD. 198/5
Key selector



COD. E010
Remote control



COD. 165B
Warning sign

KIT 2 LEAVES

CODE	MODEL	DESCRIPTION	PRICE	
112570	KIT PH1 270	Kit 2 leaves for gates up to 3,60 mt	€ 1.850,00	●
112570/1	KIT PH 270 *	Kit 2 leaves for gates up to 6 mt	€ 1.850,00	●
12384/2	KIT PH1 390	Kit 2 leaves for gates up to 10 mt	€ 1.938,00	●
12384/3	KIT PH 390 *	Kit 2 leaves for gates up to 12 mt	€ 1.938,00	●

KIT 1 LEAF

CODE	MODEL	DESCRIPTION	PRICE	
112570/3	KIT PH1 270	Kit 1 leaf for gates up to 1,80 mt	€ 1.149,00	●
112570/2	KIT PH 270 *	Kit 1 leaf for gates up to 3 mt	€ 1.149,00	●
12384/4	KIT PH1 390	Kit 1 leaf for gates up to 5 mt	€ 1.193,00	●
12384/5	KIT PH 390 *	Kit 1 leaf for gates up to 6 mt	€ 1.193,00	●



PZ. PALLET
800x1200x1200 | 14 pz. 390 KG





PHV

LINEAR HYDRAULIC OPERATOR 230V

i PHV IRREVERSIBLE: LEAF LENGTH UP TO 4 MT
 PHV REVERSIBLE: LEAF LENGTH UP TO 7 MT



INSTRUCTIONS

-  RESIDENTIAL
-  COLLECTIVE
-  POWER SUPPLY 230V
-  REVERSIBLE
-  IRREVERSIBLE

FEATURES

- Sturdy aluminum and die-casting structure
- Stroke MM 242 (PHV 240) - MM 362 (PHV 360)
- Steel rod rectified and chromed MM 20
- Very quiet operation
- Electric motor in oil bath
- Valve device for selection between reversibility or locking
- Hydraulic adjustment for thrust
- Hydraulic slowdown adjustment in closing
- Aluminum rod cover included
- Manual release with key
- 90° opening
- Quick installation with multi-position brackets
- Power supply 230V
- Limit switches in opening

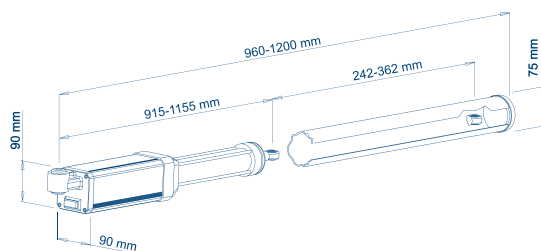

PERFORMANCE REQUIREMENTS

- Operating Cycle INTENSIVE
- Use frequency 100%
- Thrust 6252/7793 N

TECHNICAL FEATURES

	PHV 240	PHV 360
Power supply	230VAC	230VAC
Leaf weight	600 KG	800 KG
Leaf length	4 MT	7 MT
Engine RPM	50 BAR	50 BAR
Average absorption	1,1 A	1,3 A
Absorbed power	276 W	280 W
Standard limit switch	OPTIONAL	OPTIONAL
Condenser	16 UF	16 UF
Motor weight	12 KG	13,5 KG
Noise level	< 30 DBA	< 30 DBA
Enviromental conditions	-15 / +80° C	-15 / +80° C
Protection degree	100	100

OPERATORS AND ACCESSORIES

CODE	MODEL	DESCRIPTION	PRICE	
100021	PHV 240 *	Irreversible / Reversible - Stroke 242 MM - Leaf lenght up to 4 mt	€ 1.054,00	● ●
100022	PHV 360 **	Irreversible / Reversible - Stroke 362 MM - Leaf lenght up to 7 mt	€ 1.157,00	● ●
SD1	FC	Mechanical limit switch	€ 92,00	



PZ. PALLET
800x1200x1100 | 20 pz. 280 KG

- * For **PHV 240** for leaves longer than 1,80 meters, the use of the electric lock is always required
- ** For **PHV 360** for leaves longer than 2,50 meters, the use of the electric lock is always required
- For better radio reception we recommend the use of an external aerial code 210/1
- In the presence of strong wind and cold temperatures, the performance of the actuator can be significantly reduced

KIT CONTENT



COD. E105
Control board 230V



COD. 12/C
Pair of photocells



COD. 23/8
LED flashing light



COD. 198/5
Key selector



COD. E010
Remote control



COD. 165B
Warning sign

KIT 2 LEAVES

CODE	MODEL	DESCRIPTION	PRICE	
112581/1	KIT PHV 240 *	Kit 2 leaves for gates up to 8 mt	€ 2.534,00	● ●
112581/2	KIT PHV 360 **	Kit 2 leaves for gates up to 14 mt	€ 2.854,00	● ●

KIT 1 LEAF

CODE	MODEL	DESCRIPTION	PRICE	
112581/3	KIT PHV 240 *	Kit 1 leaf for gates up to 4 mt	€ 1.481,00	● ●
112581/4	KIT PHV 360 **	Kit 1 leaf for gates up to 7 mt	€ 1.697,00	● ●



PZ. PALLET
800x1200x1200 | 8 pz. 270 KG

EXTRA ACCESSORIES



COD. SD1
Mechanical limit switch

AUTOMATIONS FOR **SLIDING GATES**

Automations for Sliding Gates

SIMPLY OPERATOR 230V - 24V

GATES UP TO 600 KG



Available with
**MECHANICAL OR
MAGNETIC LIMIT
SWITCH**

Available with
**FAST VERSION
220V/110V 20 MT/MIN**



INSTRUCTIONS



RESIDENTIAL



COLLECTIVE



POWER SUPPLY 230V - 24V

**700.000
UNITS SOLD**

FEATURES

- Structure in die-cast aluminum, powder painted
- Steel and cast gears obtained from solid
- Lithium grease lubrications of mechanical parts against corrosion, oxidation and rust
- Very quiet operation
- High Performance electric motor
- Lever release with custom key
- Available with or without Encoder
- Electronic torque control
- Pre-wiring and easy programming software
- Available with or without control unit
- Control unit box with air-stop seal against moisture and insects
- Anti-squashing system * (EN 12453)
- Slowing down function * (EN 12453)
- Optional kit battery back-up
- Power supply 230V - 24V

* Functions guaranteed with VDS electronics devices

PERFORMANCE REQUIREMENTS

- Operating Cycle SEMI-INTENSIVE 230V, INTENSIVE 24V
- Use frequency 50% (230VAC) - 80% (24VCC)
- Speed 10 MT/MIN (230VAC) - 12 MT/MIN (24VCC)

TECHNICAL FEATURES

	SIMPLY 230	SIMPLY 24
Power supply	230VAC	24VAC
Leaf weight	600 KG	400/600 KG
Pinion	M4-Z12	M4-Z12
Engine RPM	1400 RPM	1800 RPM
Average absorption	1,3 A	3 A
Absorbed power	250 W	50 W
Condenser	12,5 UF	-
Motor weight	8 KG	8 KG
Noise level	< 30 DBA	< 30 DBA
Enviromental conditions	-20 / +55° C	-20 / +55° C
Protection degree	IP44	IP44

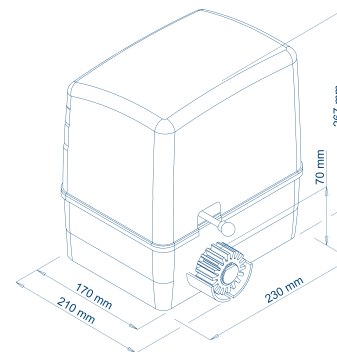

OPERATORS AND ACCESSORIES

CODE	MODEL	DESCRIPTION	PRICE
100010	SIMPLY 230V *	Operator - Without control board	€ 333,00
100010/1	SIMPLY 230V CQ *	Operator - Control board and built-in receiver 433 mHz	€ 530,00
100011	SIMPLY 24V *	Operator - Without control board	€ 372,00
100011/1	SIMPLY 24V CQ *	Operator - Control board and built-in receiver 433 mHz	€ 600,00
140063	CPT	Fixing plate	€ 24,00
FC003	FCM	Extra for magnetic limit switch	€ 75,00
EN001	EN CDR	Extra for encoder	€ 46,00
CPT-B	VERS. B	Adapter fixing plate for sliding motor B	€ 50,00
CPT-C	VERS. C	Adapter fixing plate for sliding motor C	€ 50,00
CPT-F	VERS. F	Adapter fixing plate for sliding motor F	€ 50,00
CPT-N	VERS. N	Adapter fixing plate for sliding motor N	€ 50,00



PZ. PALLET
800x1200x1600 | 50 pz. 410 KG

- * Fixing plate not included
- For better radio reception we recommend the use of an external aerial code 210/1
- In presence of strong wind and cold temperatures, the performance of the actuator can be significantly reduced

KIT CONTENT

The kit contains **1 control board** + accessories



PZ. PALLET
800x1200x1300 | 32 pz. 330 KG



COD. E102
Control board 230V



COD. E103
Control board 24V



COD. 12/C
Pair of photocells



COD. 23/8
LED flashing light



COD. 198/5
Key selector



COD. E010
Remote control



COD. 165B
Warning sign

CODE	MODEL	DESCRIPTION	PRICE
100010/6	KIT SIMPLY 230V	Kit for gates up to 600 kg	€ 686,00
100010/7	KIT SIMPLY 24V	Kit for gates up to 600 kg	€ 763,00
100010/2	KIT SIMPLY 230V 2M	Kit 2 leaves for gates up to 600 kg	€ 1.075,00



COD. 140063
Fixing plate

EXTRA ACCESSORIES



COD. FC003
Magnetic limit switch



COD. 140063
Fixing plate



COD. CPT-B
Adapter plate for compatibility with other brands



COD. CPT-C
Adapter plate for compatibility with other brands



COD. CPT-F
Adapter plate for compatibility with other brands



COD. CPT-N
Adapter plate for compatibility with other brands

Automations for Sliding Gates

GEKO OPERATOR 230V

i GATES UP TO 400 KG



INSTRUCTIONS



RESIDENTIAL



COLLECTIVE



POWER SUPPLY 230V



IRREVERSIBLE

FEATURES

- Structure in die-cast aluminum, powder painted
- Steel and cast gears obtained from solid
- Lithium grease lubrications of mechanical parts against corrosion, oxidation and rust
- Very quiet operation
- High Performance electric motor
- Lever release with custom key
- Electronic torque control
- Pre-wiring and easy programming software
- Available with or without control unit
- Control unit box with air-stop seal against moisture and insects
- Anti-squashing system * (EN 12453)
- Power supply 230V

* Functions guaranteed with VDS electronics devices

PERFORMANCE REQUIREMENTS

- Operating Cycle SEMI-INTENSIVE 230VAC
- Use frequency 50% (230VAC)
- Speed 10 MT/MIN (230VAC)

TECHNICAL FEATURES

Power supply	230VAC
Leaf weight	400 KG
Pinion	M4-Z12
Engine RPM	1400 RPM
Average absorption	1,3 A
Absorbed power	250 W
Condenser	10 UF
Motor weight	8 KG
Noise level	< 30 DBA
Enviromental conditions	-20 / +55° C
Protection degree	IP44

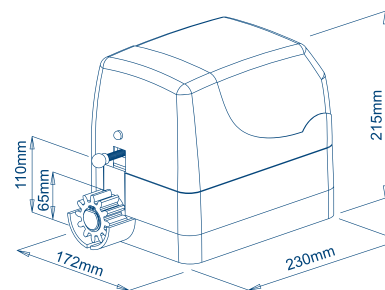

OPERATORS AND ACCESSORIES

CODE	MODEL	DESCRIPTION	PRICE
11090	GEKO 230V	Operator - Without control board	€ 299,00
11090/1	GEKO 230V CQ	Operator - Control board and built-in receiver 433 MHz	€ 495,00
CPT04	CPT	Fixing plate	€ 24,00

 PZ. PALLET
80x1200x1600 | 50 pz. 410 KG

KIT CONTENT

The kit contains **1 control board** + accessories

 PZ. PALLET
80x1200x1300 | 32 pz. 330 KG



COD. E102
Control board 230V



COD. 12/C
Pair of photocells



COD. 23/8
LED flashing light



COD. 198/5
Key selector



COD. E010
Remote control



COD. 165B
Warning sign

CODE	MODEL	DESCRIPTION	PRICE
11090/2	KIT GEKO 230V	Kit for gates up to 400 kg	€ 647,00



COD. CPT04
Fixing plate

EXTRA ACCESSORIES



COD. CPT04
Fixing plate

Automations for Sliding Gates

CARRERA

OPERATOR 230V - 24V

GATES UP TO 1000 KG



INSTRUCTIONS

-  RESIDENTIAL
-  COLLECTIVE
-  POWER SUPPLY 230V - 24V

FEATURES

- Structure in die-cast aluminum, powder painted
- Steel and cast gears obtained from solid
- Lithium grease lubrications of mechanical parts against corrosion, oxidation and rust
- Very quiet operation
- High Performance electric motor
- Lever release with custom key
- Available with or without Encoder
- Electronic torque control
- Pre-wiring and easy programming software
- Available with or without control board
- Control board box with air-stop seal against moisture and insects
- Anti-squashing system * (EN 12453)
- Slowing down function * (EN 12453)
- Optional kit battery back-up
- Power supply 230V - 24V

* Functions guaranteed with VDS electronics devices

PERFORMANCE REQUIREMENTS

- Operating Cycle SEMI-INTENSIVE 230V, INTENSIVE 24V
- Use frequency 50% (230VAC) - 80% (24VCC)
- Speed 10 MT/MIN (230VAC) - 12 MT/MIN (24VCC)

TECHNICAL FEATURES

	CARRERA 800-230	CARRERA 800-24	CARRERA 1000-230
Power supply	230VAC	24VCC	230VAC
Leaf weight	800 KG	800 KG	1000 KG
Pinion	M4-Z16	M4-Z16	M4-Z16
Engine RPM	1400 RPM	1800 RPM	1400 RPM
Average absorption	2 A	3 A	2 A
Absorbed power	330 W	50 W	330 W
Condenser	10 UF	-	12,5 UF
Motor weight	9 KG	9 KG	9 KG
Noise level	< 30 DBA	< 30 DBA	< 30 DBA
Environmental conditions	-20 / +55° C	-20 / +55° C	-20 / +55° C
Protection degree	IP44	IP44	IP44

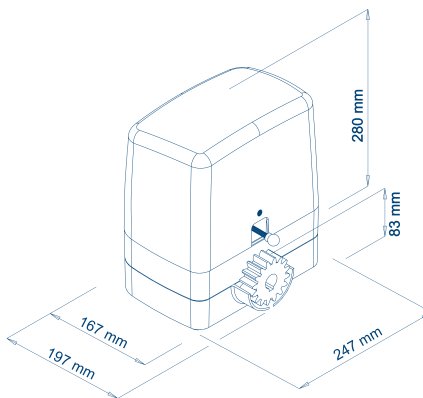

Available with
MECHANICAL OR
MAGNETIC LIMIT
SWITCH

Available with
FAST VERSION
220V/110V 20 MT/MIN

OPERATORS AND ACCESSORIES

CODE	MODEL	DESCRIPTION	PRICE
100600	CARRERA 800 230V *	Operator - Up to 800 kg - Without control board	€ 398,00
100609/E	CARRERA 800 24V C/ENCDR *	Operator - Up to 800 kg - Without control board	€ 438,00
100601	CARRERA 1000 230V *	Operator - Up to 1000 kg - Without control board	€ 458,00
100602	CARRERA 800 230V CQ *	Operator - Up to 800 kg - Control board and built-in receiver 433 mHz	€ 536,00
100609	CARRERA 800 24V CQ *	Operator - Up to 800 kg - Control board and built-in receiver 433 mHz	€ 608,00
100604	CARRERA 1000 230V CQ *	Operator - Up to 1000 kg - Control board and built-in receiver 433 mHz	€ 597,00
100607	CPT	Fixing plate	€ 24,00
FC004	FCM	Extra for magnetic limit switch	€ 75,00
EN001	ENCDR	Extra for encoder	€ 46,00



PZ. PALLET
800x1200x1600 | 40 pz. 400 KG

- * Fixing plate not included
- For better radio reception we recommend the use of an external aerial code 210/1
- In presence of strong wind and cold temperatures, the performance of the actuator can be significantly reduced

KIT CONTENT

The kit contains **1 control board** + accessories



PZ. PALLET
800x1200x1500 | 32 pz. 430 KG



COD. E102
Control board 230V



COD. E103
Control board 24V



COD. 12/C
Pair of photocells



COD. 23/8
LED flashing light



COD. 198/5
Key selector



COD. E010
Remote control



COD. 165B
Warning sign

CODE	MODEL	DESCRIPTION	PRICE
100605	KIT CARRERA 800 230V	Kit for gates up to 800 kg	€ 760,00
10606	KIT CARRERA 800 24V	Kit for gates up to 800 kg	€ 979,00
100606	KIT CARRERA 1000 230V	Kit for gates up to 1000 kg	€ 820,00



COD. 140607
Fixing plate

EXTRA ACCESSORIES



COD. FC004
Magnetic limit switch



COD. 140607
Fixing plate

Automations for Sliding Gates

AG FUTURE OPERATOR 230V - 380V

GATES UP TO 1800 KG



INSTRUCTIONS

RESIDENTIAL

COLLECTIVE

POWER SUPPLY 230V - 380V

IN OIL BATH

FEATURES

- Structure in die-cast aluminum, powder painted
- Steel and cast gears obtained from solid
- Stator and mechanical parts in oil bath - except 800 kg version, grease lubricated
- Available with or without control board
- Control board with built-in receiver and antenna, control unit box with air-stop seal against moisture and insects
- Pre-wiring and easy programming software
- High Performance electric motor
- Manual lever release with custom key
- Electronic torque control
- Very quiet operation
- Anti-squashing system * (EN 12453)
- Slowing down function * (EN 12453)
- The 1800 kg three-phase version comes with a control board with soft start and stop function
- Power supply 230V - 380V

* Functions guaranteed with VDS electronics devices

PERFORMANCE REQUIREMENTS

- Operating Cycle SEMI-INTENSIVE 230V, INTENSIVE 380V
- Use frequency 50% (230VAC) - 80% (380VAC)
- Speed 8 MT/MIN (230VAC) - 8 MT/MIN (380VAC)



TECHNICAL FEATURES

	AG FUTURE 800 KG	AG FUTURE 1000 KG	AG FUTURE 1600 KG	AG FUTURE 1600 KG TRIFASE	AG FUTURE 1600 KG TRIFASE INVERTER
Power supply	230VAC	230VAC	230VAC	380VAC	230VAC
Leaf weight	800 KG	1000 KG	1600 KG	1600 KG	1800 KG
Pinion	M4-Z16	M4-Z16	M4-Z16	M4-Z16	M4-Z16
Engine RPM	1400 RPM	1400 RPM	1400 RPM	1400 RPM	1400 RPM
Average absorption	1,5 A	1,7 A	1,8 A	1,5 A	1,5 A
Absorbed power	280 W	330 W	360 W	500 W	400 W
Condenser	12,5 UF	16 UF	18 UF	-	-
Motor weight	13 KG	13 KG	13 KG	13 KG	13 KG
Noise level	< 30 DBA	< 30 DBA	< 30 DBA	< 30 DBA	< 30 DBA
Environmental conditions	-20 / +55° C	-20 / +55° C	-20 / +55° C	-20 / +55° C	-20 / +55° C
Protection degree	IP44	IP44	IP44	IP44	IP44

Available with
MECHANICAL OR
MAGNETIC LIMIT
SWITCH

Available with
FAST VERSION
220V/110V 20 MT/MIN

OPERATORS AND ACCESSORIES

CODE	MODEL	DESCRIPTION	PRICE
11068	AG F 800 KG **	Operator - Up to 800 kg - Without control board	€ 492,00
11065	AG F 1000 KG *	Operator - Up to 1000 kg - Without control board	€ 552,00
11066	AG F 1600 KG *	Operator - Up to 1600 kg - Without control board	€ 641,00
11067	AG F 1600 KG TRIFASE 380VAC *	Operator - Up to 1600 kg - Without control board	€ 658,00
11068/1	AG F 800 KG CQ **	Operator - Up to 800 kg - With control board and receiver	€ 630,00
11065/1	AG F 1000 KG CQ *	Operator - Up to 1000 kg - With control board and receiver	€ 691,00
11066/1	AG F 1600 KG CQ *	Operator - Up to 1600 kg - With control board and receiver	€ 697,00
11069/1	AG F 1800 KG 230VAC CQ INVERTER*	Operator - Up to 1800 kg - With inverter control board - Witht riceiver	€ 1.231,00
CPT02	CPT	Fixing plate	€ 41,00
FC005	AG FUTURE FCM	Extra for magnetic limit switch	€ 75,00



PZ. PALLET
800x1200x1600 | 35 pz. 490 KG

- * Fixing plate not included
- For better radio reception we recommend the use of an external aerial code 210/1
- In presence of strong wind and cold temperatures, the performance of the actuator can be significantly reduced

KIT CONTENT

The kit contains **1 control board** + accessories



PZ. PALLET
800x1200x1000 | 24 pz. 432 KG



COD. E102
Control board 230V



COD. E107
Control board 380V



COD. 12/C
Pair of photocells



COD. 23/8
LED flashing light



COD. 198/5
Key selector



COD. E010
Remote control



COD. 165B
Warning sign

COD	MOD	DESCRIPTION	PRICE
11068/2	KIT AG F 800 KG *	Kit for gates up to 800 kg	€ 853,00
11065/2	KIT AG F 1000 KG *	Kit for gates up to 1000 kg	€ 914,00
11066/2	KIT AG F 1600 KG *	Kit for gates up to 1600 kg	€ 1.002,00



COD. CPT02
Fixing plate

EXTRA ACCESSORIES

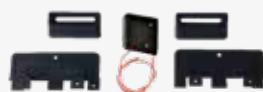

COD. FC005
Magnetic limit switch



COD. CPT02
Fixing plate

Automations for Sliding Gates

AT PLUS

OPERATOR 230V - 380V

GATES UP TO 2500 KG



INSTRUCTIONS



RESIDENTIAL



COLLECTIVE



POWER SUPPLY 230V - 380V



IN OIL BATH

FEATURES

- Structure in die-cast aluminum, powder painted
- Steel and cast gears obtained from solid
- Stator and mechanical parts in oil bath
- Available with or without control board
- Control unit with built-in receiver and antenna, control board box with air-stop seal against moisture and insects
- Pre-wiring and easy programming software
- High Performance electric motor
- Mechanical limit switch
- Manual lever release with custom key
- Electronic torque control
- Very quiet operation
- Anti-squashing system * (EN 12453)
- Slowing down function * (EN 12453)
- Power supply 230V - 380V

* Functions guaranteed with VDS electronics devices

PERFORMANCE REQUIREMENTS

- Operating Cycle INTENSIVE 230VAC, INTENSIVE 380VAC
- Use frequency 90% (230VAC) - 90% (380VAC)
- Speed 9,6 MT/MIN (230VAC) - 9,6 MT/MIN (380VAC)

TECHNICAL FEATURES

	AT PLUS 2500	AT PLUS 2500 TRIPHASE
Power supply	230VAC	380VAC
Leaf weight	2500 KG	2500 KG
Pinion	M4-Z16	M4-Z16
Engine RPM	1400 RPM	1400 RPM
Average absorption	2,4 A	2,4 A
Absorbed power	650 W	650 W
Condenser	12,5 UF	-
Motor weight	18 KG	18 KG
Noise level	< 30 DBA	< 30 DBA
Environmental conditions	-20 / +55° C	-20 / +55° C
Protection degree	IP44	IP44

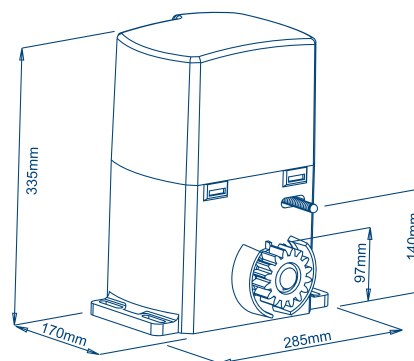

OPERATORS

CODE	MODEL	DESCRIPTION	PRICE
A3500	AT PLUS 230V	Operator - Up to 2500 kg - Fixing plate - Without control board	€ 916,00
A3500/1	AT PLUS TRIPHASE 380V	Operator - Up to 2500 kg - Three-phase 380V - Fixing plate - Without control board	€ 934,00
10035/1	AT PLUS 230V CQ	Operator - Up to 2500 kg - Fixing plate - Control board and built-in receiver 433 MHz	€ 1.044,00



PZ. PALLET
800x1200x1600 | 26 pz. 460 KG

- For better radio reception we recommend the use of an external aerial code 210/1
- In presence of strong wind and cold temperatures, the performance of the actuator can be significantly reduced

KIT CONTENT

The kit contains **1 control board** + accessories



COD. E102
Control board 230V



COD. E107
Control board 380V



COD. 12/C
Pair of photocells



COD. 23/8
LED flashing light



COD. 198/5
Key selector



COD. E010
Remote control



COD. 165B
Warning sign

CODE	MODEL	DESCRIPTION	PRICE
10035	KIT AT PLUS 2500 230V	Kit for gates up to 2500 kg	€ 1.494,00
10035/T	KIT AT PLUS 2500 380V	Kit for gates up to 2500 kg	€ 1.941,00



PZ. PALLET
800x1200x1000 | 25 pz. 450 KG

TOM

OPERATOR 230 Δ - 400Y VAC

GATES UP TO 5000 KG



INSTRUCTIONS



COLLECTIVE



POWER SUPPLY 230V - 380V

FEATURES

- Structure in painted steel and stainless steel, cover in ABS
- Steel and bronze gears obtained from solid
- Air-cooled motor and gearbox in oil bath
- Available with or without control unit
- External control unit with watertight box
- High Performance electric motor
- Mechanical limit switch
- Manual release with hex key
- Very quiet operation
- Motor not provided with clutch, provide with safety equipment
- Motor door safety microswitch
- Three-phase motor 230 - 400Y VAC

* Functions guaranteed with VDS electronics devices



PERFORMANCE REQUIREMENTS

- Operating Cycle INTENSIVE
- Use frequency 90%
- Speed 8 MT/MIN

TECHNICAL FEATURES

Power supply	230 Δ - 400Y VAC
Leaf weight	4000 KG - 380V* 5000 KG - TRIPHASE INVERTER
Pinion	Z20
Engine RPM	1400 RPM
Average absorption	2,5 A
Absorbed power	750 W
Motor weight	40 KG
Noise level	< 30 DBA
Enviromental conditions	-25 / +70° C
Protection degree	IP54
Limit switch	ELECTROMECHANICAL

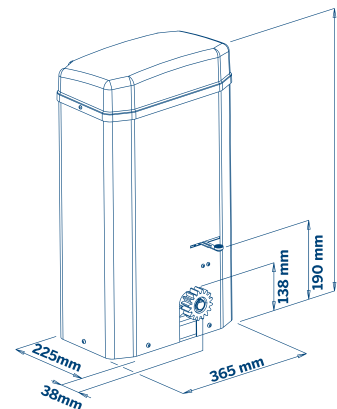

Toothed pinion suitable for MODULE 4 RACKS

OPERATORS AND ACCESSORIES

CODE	MODEL	DESCRIPTION	PRICE
11040	TOM 230 - 400Y - M4	Operator - Up to 5000 kg - Without contro board - With pinion M4	€ 2.354,00
11040/1	TOM 230 - 400Y - M6	Operator - Up to 5000 kg - Without contro board - With pinion M6	€ 2.461,00
121110	CPT	Fixing plate	€ 73,00
Q100	INVERTER	Contro board 230V - Inverter - Without receiver	€ 779,00
E107	EURO 380 M1	Contro board 230/380VAC	€ 567,00
E142	SRM	External radio receiver 433 mHz 1 channel - With box 12/24V	€ 97,00
AC01-100	100A	Galvanized cabinet with key for control board	€ 353,00
AC01-200VA	200V	Support for control board	€ 207,00



PZ. PALLET
800x1200x70 | 6 pz. 300 KG

- In presence of strong cold temperatures, the performance of the actuator can be significantly reduced

EXTRA ACCESSORIES



COD. 121110
Fixing plate



COD. Q100
Control board 230V Inverter



COD. E107
Control board 230V - 380V

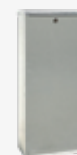

COD. AC01-100
Galvanized cabinet with key
for control board



COD. AC01-200VA
Support for control board



COD. E142
External radio receiver
433mHz



COD. 23/8
LED flashing light



COD. 12/C
Pair of photocells



COD. 165B
Warning sign



COD. E010
Remote control



COD. 198/5
Key selector

Automations for Sliding Gates

SLIM VULCAN

OPERATOR 230V - 24V

GATES UP TO 250 KG



Suitable for application
inside pillars



INSTRUCTIONS



RESIDENTIAL



POWER SUPPLY 230V - 24V

FEATURES

- Operator 24V with Encoder - Operator 230V without Encoder
- It works also without mechanical limit switch
- High Performance electric motor
- Very quiet operation
- Control board with built-in receiver and antenna, control board box with air-stop seal against moisture and insects
- Pre-wiring and easy programming software
- Manual release with hex key
- Electronic torque control
- Anti-squashing system * (EN 12453)
- Slowing down function * (EN 12453)
- Anti blackout battery kit
- Power supply 230V - 24V

* Functions guaranteed with VDS electronics devices

PERFORMANCE REQUIREMENTS

- Operating Cycle SEMI-INTENSIVE 230V, INTENSIVE 24V
- Emergency release with key
- Speed 10 MT/MIN (230VAC) - 10 MT/MIN (24VCC)

TECHNICAL FEATURES

	SLIM VULCAN 230	SLIM VULCAN 24
Power supply	230VAC	24VCC
Leaf weight	250 KG	200 KG
Engine RPM	1400 RPM	1800 RPM ENCODER
Average absorption	1 A	3 A
Absorbed power	200 W	50 W
Condenser	12,5 UF	-
Motor weight	4,5 KG	4 KG
Noise level	< 30 DBA	< 30 DBA
Limit switch	OPTIONAL	OPTIONAL
Protection degree	IP44	IP44

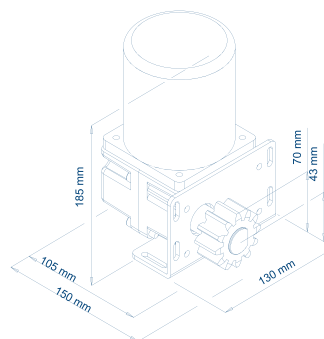
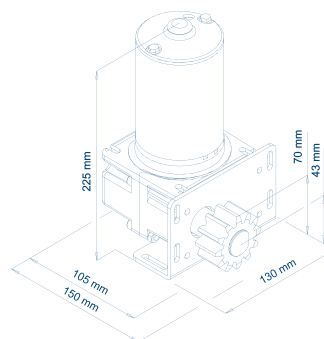

OPERATORS AND ACCESSORIES

CODE	MODEL	DESCRIPTION	PRICE
10009/P	SLIM 230V	Operator - Up to 350 kg - Fixing plate - Without control board	€ 287,00
10009/E	SLIM 230V	Operator - Up to 350 kg - Fixing plate - Encoder - Without control board	€ 333,00
10081/ENC	SLIM 24V	Operator - Up to 350 kg - Fixing plate - Encoder - Without control board	€ 338,00
FC001	FC MEC	Mechanical limit switch	€ 62,00
FC002	FC MAG	Magnetic limit switch	€ 75,00



PZ. PALLET
800x1200x1600 | 50 pz. 230 KG

- For better radio reception we recommend the use of an external aerial code 210/1
- In presence of strong cold temperatures, the performance of the actuator can be significantly reduced

KIT CONTENT

The kit contains **1 control board** + accessories



PZ. PALLET
800x1200x1000 | 25 pz. 450 KG



COD. E102
Control board 230V



COD. E103
Control board 24V



COD. 12/C
Pair of photocells



COD. 23/8
LED flashing light



COD. 198/5
Key selector



COD. E010
Remote control



COD. 165B
Warning sign

COD	MOD	DESCRIZIONE	PREZZO
10009/K	SLIM 230	Kit Slim Vulcan 230V - mechanical limit switch	€ 687,00
10009/KE	SLIM 230E	Kit Slim Vulcan 230V with Encoder - mechanical limit switch	€ 722,00
10081/KE	SLIM 24E	Kit Slim Vulcan 24V with Encoder - mechanical limit switch	€ 753,00
10009/KM	SLIM 230	Kit Slim Vulcan 230V - with magnetic limit switch	€ 765,00
10009/KEM	SLIM 230E	Kit Slim Vulcan 230V with Encoder - magnetic limit switch	€ 808,00
10081/KEM	SLIM 24E	Kit Slim Vulcan 24V with Encoder - magnetic limit switch	€ 829,00

EXTRA ACCESSORIES



COD. FC002
Mechanical limit switch



COD. FC001
Magnetic limit switch



The background consists of a solid orange triangle on the left side, pointing towards the top right, and a solid blue area on the right side.

AUTOMATIONS FOR **GARAGE DOORS**

Automations for Garage Doors

UTILE

TOWING ELECTROMECHANICAL OPERATOR 24V

i DOOR WEIGHT UP 100 KG



INSTRUCTIONS



RESIDENTIAL



COLLECTIVE



POWER SUPPLY 24V

FEATURES

- Operator Encoder
- Suitable for sectional and counterweight doors (with curved arm)
- Galvanized iron or aluminum guide with pre-assembled chain or belt
- Lithium grease lubrications of mechanical parts against corrosion, oxidation and rust
- High Performance electric motor
- Very quiet operation
- Limit switches / Encoder
- Magnetic contact for pedestrian
- Pre-wiring and easy programming software
- Control board with built-in receiver and antenna
- Electronic torque control
- Anti-squashing system * (EN 12453)
- Slowing down function * (EN 12453)
- Power supply 24V

* Functions guaranteed with VDS electronics devices

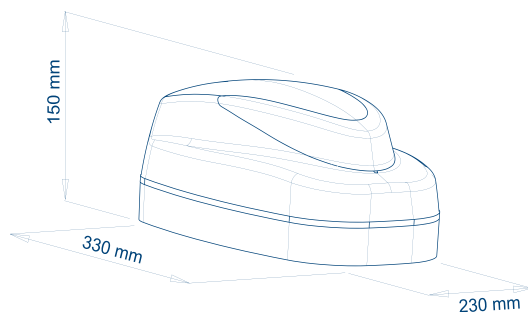

PERFORMANCE REQUIREMENTS

	UTILE 70KG	UTILE 100KG
Power supply	24VCC	24VCC
Thrust	700 N	1000 N
Door weight	10 MQ	14 MQ
Engine RPM	220 RPM	220 RPM
Average absorption	0,7 A	1,2 A
Pinion	1/2"X1/8 Z9 PASSO 8 Z12	1/2"X1/8 Z9 PASSO 8 Z12
Motor weight	4 KG	4 KG
Noise level	< 30 DBA	< 30 DBA
Enviromental conditions	-20 / +55° C	-20 / +55° C
Protection degree	IP30	IP30

Courtesy light with LOW CONSUMPTION LED

OPERATORS

CODE	MODEL	DESCRIPTION	PRICE
11085	UTILE 70 KG	Operator - Control board - Belt - Iron guide 3 mt	€ 476,00
11084	UTILE 70 KG	Operator - Control board - Chain - Iron guide 3 mt	€ 450,00
11087	UTILE 70 KG	Operator - Control board - Belt - Aluminum guide 1,5 mt + 1,5 mt	€ 499,00
11086	UTILE 70 KG	Operator - Control board - Chain - Aluminum guide 1,5 mt + 1,5 mt	€ 473,00
11085/2	UTILE 70 KG	Operator - Control board - Belt - Aluminum guide 2 mt + 2 mt	€ 538,00
11084/2	UTILE 70 KG	Operator - Control board - Chain - Aluminum guide 2 mt + 2 mt	€ 514,00
11085/1	UTILE 100 KG	Operator - Control board - Belt - Iron guide 3 mt	€ 542,00
10084/1	UTILE 100 KG	Operator - Control board - Chain - Iron guide 3 mt	€ 517,00
11087/1	UTILE 100 KG	Operator - Control board - Belt - Aluminum guide 1,5 mt + 1,5 mt	€ 565,00
11086/1	UTILE 100 KG	Operator - Control board - Chain - Aluminum guide 1,5 mt + 1,5 mt	€ 539,00
11084/3	UTILE 100 KG	Operator - Control board - Chain - Aluminum guide 2 mt + 2 mt	€ 628,00
11085/3	UTILE 100 KG	Operator - Control board - Belt - Aluminum guide 2 mt + 2 mt	€ 602,00



PZ. PALLET
800x1200x1000 | 32 pz. 240 KG
+ BEAM 800x300x50 120 KG

• For better radio reception we recommend the use of an external aerial code 210/1

EXTRA ACCESSORIES

CODE	MODEL	DESCRIPTION	PRICE
100084/2	ARCHETTO	Curved arm for counterweight doors	€ 129,00
122004/1	SBLOCCO UTILE	Release with lock for sectional doors	€ 35,00
1811/1	SBLOCCO UTILE	Release for existing handle for sectional doors	€ 35,00
ST-450		Magnetic contact for overhead doors	€ 80,00

EXTRA ACCESSORIES



COD. 100084/2
Curved arm for counterweight doors



COD. ST-450
Magnetic contact for overhead doors



COD. 122004/1
Release with lock for sectional doors



COD. 1811/1
Release for existing handle for sectional doors



COD. E010
Remote control



COD. 12/C
Pair of photocells



COD. 23/8
LED flashing light



COD. 23/4
Wall fixing base



COD. 198/5
Key selector



COD. 165B
Warning sign

Automations for Garage Doors

BASIC 09

ELECTROMECHANICAL OPERATOR 230V - 24V

i MAX SURFACE 10 MQ



INSTRUCTIONS

RESIDENTIAL

COLLECTIVE

POWER SUPPLY 230V - 24V

IRREVERSIBLE

FEATURES

- Irreversible electromechanical operator
- Steel and bronze gears obtained from solid
- Very quiet operation
- Lithium grease lubrications of mechanical parts against corrosion, oxidation and rust
- High Performance electric motor
- Operator 24V with Encoder
- Operator 230V with Encoder optional
- Start button placed on cover
- Release device with die-cast lever
- Available with or without control board
- Control board with built-in receiver and antenna
- Pre-wiring and easy programming software
- Electronic torque control
- Anti-squashing system * (EN 12453)
- Slowing down function * (EN 12453)
- Courtesy light
- Power supply 230V - 24V with Encoder
- Magnetic contact for pedestrian

* Functions guaranteed with VDS electronics devices

PERFORMANCE REQUIREMENTS

- Operating Cycle SEMI-INTENSIVE 230V, INTENSIVE 24V
- Use frequency 50% (230VAC) - 80% (24VCC)
- Opening time 15 SEC

TECHNICAL FEATURES

	BASIC 09 230	BASIC 09 24
Power supply	230VAC	24V
Door weight	10 MQ	10 MQ
Engine RPM	1400 RPM	1800 RPM
Average absorption	1,3 A	3 A
Absorbed power	250 W	50 W
Condenser	12,5 UF	-
Motor weight	8,5 KG	8,5 KG
Noise level	< 30 DBA	< 30 DBA
Enviromental conditions	-20 / +55° C	-20 / +55° C
Protection degree	IP30	IP30
Max torque	200 NM	200 NM

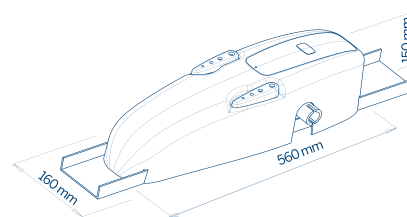

NO SOLDERING
REQUIRED

Available also with
BROACHED SHAFT

OPERATORS

CODE	MODEL	DESCRIPTION	PRICE
759/09	BASIC 09 - 230V	Operator - Without control board	€ 396,00
110411/09	BASIC 09 - 230V	Operator - Control board and built-in receiver 433 MHz	€ 578,00
100034/09E	BASIC 09 - 24V	Operator - Control board and built-in receiver 433 MHz - Encoder	€ 731,00
EN002	ENCODER	Extra for Basic Encoder 230V	€ 46,00



PZ. PALLET
800x1200x1100 | 35 pz. 340 KG

• For better radio reception we recommend the use of an external aerial code 210/1

EXTRA ACCESSORIES



COD. CNT
Counterweight 1.5 kg
overhead doors



COD. 112530/2 - 112530/3
Straight arms kit



COD. 112530/1 - 112530/4
Curved arms kit



COD. 756
Support bar



COD. ST-450
Magnetic contact for
overhead doors



COD. 122004/09
Release with Basic lock



COD. 12/C
Pair of photocells



COD. LD11
LED flasher



COD. 23/8
LED flashing light



COD. 23/4
Wall fixing base



COD. 198/5
Key selector



COD. E010
Remote control



COD. 165B
Warning sign

CODE	MODEL	DESCRIPTION	PRICE
CNT	CNT1	Counterweight 1.5 kg for overhead doors 20 mm	€ 36,00
122004/09	SBL SERR	Release with Basic lock	€ 37,00
756	LNG	Galvanized support bar 150 cm	€ 91,00
756/4	LNG	Galvanized support bar 200 cm	€ 118,00
112530/1	ACC. KIT 1 MONOMOTORE	2 curved arms - 2 transmission shafts - 2 packs	€ 136,00
112530/2	ACC. KIT 2 MONOMOTORE	2 straight arms - 2 transmission shafts - 2 packs	€ 112,00
112530/3	ACC. KIT 3 BIMOTORE	2 straight arms - 2 packs	€ 70,00
112530/4	ACC. KIT 4 BIMOTORE	2 curved arms - 2 packs	€ 101,00
LD11	LD	LED flasher	€ 35,00
CL001	LD-CR	Multivoltage LED flashing circuit	€ 35,00
ST-450		Magnetic contact for overhead doors	€ 80,00

Automations for Garage Doors

BASIC ON

ELECTROMECHANICAL OPERATOR 230V

i MAX SURFACE 10 MQ



INSTRUCTIONS

RESIDENTIAL

COLLECTIVE

POWER SUPPLY 230V

IRREVERSIBLE

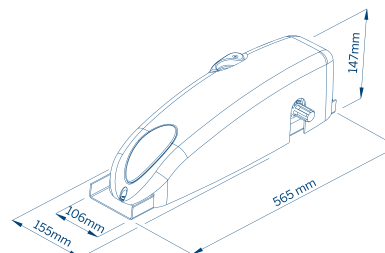

FEATURES

- Irreversible electromechanical operator
- Suitable for 2 leaves counterweight doors
- Steel and bronze gears obtained from solid
- Very quiet operation
- Lithium grease lubrications of mechanical parts against corrosion, oxidation and rust
- High Performance electric motor
- Operator 230V with Encoder optional
- Release device with die-cast lever
- Available with or without control board
- Control board with built-in receiver and antenna
- Pre-wiring and easy programming software
- Electronic torque control
- Anti-squashing system * (EN 12453)
- Slowing down function * (EN 12453)
- Courtesy light
- Power supply 230V
- Magnetic contact for pedestrian

* Functions guaranteed with VDS electronics devices

PERFORMANCE REQUIREMENTS

- Operating Cycle SEMI-INTENSIVE 230V
- Use frequency 50% (230VAC)
- Opening time 15 SEC

TECHNICAL FEATURES

Power supply	230VAC
Door weight	10 MQ
Engine RPM	1400 RPM
Average absorption	1,3 A
Absorbed power	250 W
Condenser	12,5 UF
Motor weight	8,5 KG
Noise level	< 30 DBA
Enviromental conditions	-20 / +55° C
Protection degree	IP30
Max torque	200 NM

SAXO ARMS
compatible

OPERATORS

CODE	MODEL	DESCRIPTION	PRICE
759	BASIC ON - 230V	Operator - Without control board	€ 396,00
110411	BASIC ON - 230V	Operator - Control board and built-in receiver 433 mHz	€ 578,00
EN002	ENCODER	Extra for Basic Encoder 230V	€ 46,00



PZ. PALLET
800x1200x1100 | 35 pz. 340 KG

• For better radio reception we recommend the use of an external aerial code 210/1

EXTRA ACCESSORIES



COD. CNT
Counterweight 1.5 kg
overhead doors



COD. 112529/2 - 112529/3
Straight arms kit with
broaching



COD. 112529/1 - 112529/4
Curved arms kit with
broaching



112529/5
2 Saxo arms - Accessories

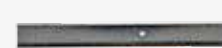

COD. 756
Support bar



COD. ST-450
Magnetic contact for
overhead doors



COD. 122004/09
Release with Basic lock



COD. 12/C
Pair of photocells



COD. LD11
LED flasher



COD. 23/8
LED flashing light



COD. 23/4
Wall fixing base



COD. 198/5
Key selector



COD. E010
Remote control



COD. 165B
Warning sign

CODE	MODEL	DESCRIPTION	PRICE
CNT	CNT1	Counterweight 1.5 kg for overhead doors	€ 36,00
122004/09	SBL SERR	Release with Basic lock	€ 37,00
756/2	LNG	Galvanized support bar 57 cm	€ 75,00
756	LNG	Galvanized support bar 150 cm	€ 91,00
756/4	LNG	Galvanized support bar 200 cm	€ 118,00
112529/1	ACC. KIT 1 MONOMOTORE	2 curved arms - 2 transmission shafts - 2 packs	€ 146,00
112529/2	ACC. KIT 2 MONOMOTORE	2 straight arms - 2 transmission shafts - 2 packs	€ 112,00
112529/3	ACC. KIT 3 BIMOTORE	2 straight arms - Accessories	€ 70,00
112529/4	ACC. KIT 4 BIMOTORE	2 curved arms - Accessories	€ 93,00
112529/ST	ACC. KIT BRACCI CURVI - SS	Curved arms kit - not to be welded	€ 271,00
112529/1ST	ACC. KIT BRACCI DRITTI - SS	Straight arms kit - not to be welded	€ 246,00
112529/5	ACC. KIT SAXO	2 Saxo arms - Accessories	€ 197,00
LD11	LD	LED flasher	€ 35,00
CL001	LD-CR	Multivoltage LED flashing circuit	€ 35,00
ST-450		Magnetic contact for overhead doors	€ 80,00

INSTALLATION EXAMPLES SECTIONAL DOOR



QTY	CODE	DESCRIPTION	PRICE
1	11086	Operator with control board - Aluminum guide 1,5+1,5 mt - With chain	€ 473,00
1	122004/1	Release with lock	€ 35,00
1	12/C	Pair of photocells Tech2	€ 64,00
1	198/5	Key selector	€ 26,00
1	E010	ECO-R remote control	€ 33,00
1	165B	Warning sign	€ 10,00

TOT
€ 641,00



INSTALLATION EXAMPLES **COUNTWEIGHT DOOR**



QTY	CODE	DESCRIPTION	PRICE
1	110411/09	Operator with control board Basic 09	€ 578,00
1	122004/09	Release with lock	€ 37,00
1	112530/2	Straight arms kit	€ 105,00
1	756	Support bar	€ 58,00
1	12/C	Pair of photocells Tech2	€ 64,00
1	198/5	Key selector	€ 26,00
1	E010	ECO-R remote control	€ 33,00
1	165B	Warning sign	€ 10,00

TOT
€ 910,00



AUTOMATIONS FOR **ROAD BARRIERS**

ITALO

ELECTROMECHANICAL BARRIER 230V

i ARMS UP TO 3 MT



INSTRUCTIONS



RESIDENTIAL



COLLECTIVE



POWER SUPPLY 230V



IRREVERSIBLE

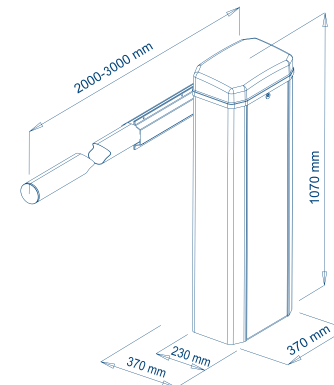

FEATURES

- Irreversible, intensive use
- Powder coated steel structure
- Motor box in cast aluminum
- Steel and bronze gears
- High Performance electric motor
- Air cooling by fan
- Mechanical parts lubricated with oil
- Opening and closing microswitches
- Spring balance
- Round arm standard - Rectangular arm optional
- Emergency release by knob
- Arm length max 3 mt / arm kit LED (optional)
- Pre-wiring and easy programming software
- Control board with built-in receiver and antenna
- Anti-squashing system * (EN 12453)
- Mechanical slowdown of opening and closing
- Electronic torque control

* Functions guaranteed with VDS electronics devices

PERFORMANCE REQUIREMENTS

- Operating Cycle **INTENSIVE**
- Use frequency 100%
- Opening time 3 SEC

TECHNICAL FEATURES

Power supply	230VAC
Max lenght arm	3 MT
Opening time	3 SEC
Absorbed power	250 W
Motor weight	45 KG
Noise level	< 30 DBA
Enviromental conditions	-20 / +55° C
Protection degree	IP44

BARRIER

CODE	MODEL	DESCRIPTION	PRICE
1447	ITALO 230V	Barrier - Control board and built-in receiver 433 mHz	€ 2.175,00



PZ. PALLET
800x1200x1200 | 6 pz. 340 KG

• For better radio reception we recommend the use of an external aerial code 210/1

EXTRA ACCESSORIES



COD. 121854 /1
Round arm, Ø 80mm



COD. 242
Fixed rod support



COD. 141
Mobile amortized rod support



COD. 121110
Fixing plate



COD. 142
Mobile curtain



COD. 150/8038
Shockproof mechanical protection



COD. LD10
Round arm LED



COD. 124512
Reflective stickers

CODE	MODEL	DESCRIPTION	PRICE
121854	AT2	Round arm, Ø 80 mm - 2 mt	€ 135,00
121854/1	AT3	Round arm, Ø 80 mm - 3 mt	€ 195,00
121110	CPT	Fixing plate	€ 41,00
242	SUPP	Fixed rod support	€ 87,00
141	AST	Mobile amortized rod support	€ 73,00
142	SIE	Mobile curtain - 2 mt	€ 119,00
LD10	LED - T	1 LED for round arm	€ 35,00
CL001	LD - CR	Multivoltage LED flashing circuit	€ 35,00
124512	ACTR	Reflective stickers (pack of 6 pcs)	€ 18,00
150/8038	PRT	Shockproof mechanical protection	€ 229,00

BERTA

ELECTROMECHANICAL BARRIER 230V -24V

i ARMS UP TO 6 MT



INSTRUCTIONS

RESIDENTIAL

COLLECTIVE

POWER SUPPLY 230V - 24V

IRREVERSIBLE

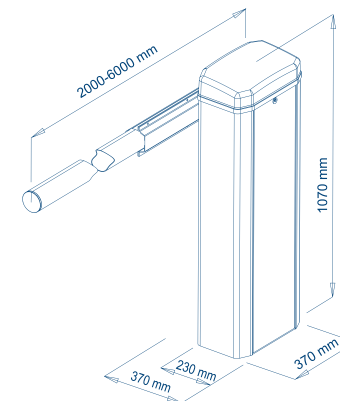

FEATURES

- Irreversible, intensive use
- Powder coated steel structure
- Motor box in cast aluminum
- Steel and cast iron gears
- High Performance electric motor
- Mechanical parts lubricated with lithium grease
- Opening and closing microswitches
- Spring balance
- Round arm standard - Rectangular arm optional
- Emergency release by crank, 230V
- Mechanical release with key, 24V
- Arm length max 6 mt / arm kit LED (optional)
- Pre-wiring and easy programming software
- Control board with built-in receiver and antenna
- Anti-squashing system * (EN 12453)
- Slowing down function * (EN 12453)
- Electronic torque control
- Anti black out battery kit

* Functions guaranteed with VDS electronics devices

PERFORMANCE REQUIREMENTS

- Operating Cycle SEMI-INTENSIVE 230V, INTENSIVE 24V
- Use frequency 50% (230VAC) - 100% (24 CC)
- Opening time 10 SEC

TECHNICAL FEATURES

	BERTA 230	BERTA 24
Power supply	230 VAC	24 VCC
Max lenght arm	6 MT	6 MT
Opening time	10 SEC	10 SEC
Absorbed power	250 W	60 W
Motor weight	45 KG	45 KG
Noise level	< 30 DBA	< 30 DBA
Enviromental conditions	-20 / +55° C	-20 / +55° C
Protection degree	IP44	IP44

BARRIERS

CODE	MODEL	DESCRIPTION	PRICE
1445	BERTA 230V	Barrier - Control board - Arm from 3 to 6 mt	€ 1.878,00
1445/2	BERTA 230V FAST	Barrier - Control board - Arm from 2 to 4 mt	€ 1.878,00
1446	BERTA 24V	Barrier - Control board - Arm from 3 to 6 mt	€ 1.936,00
1446/3	BERTA 24V FAST 3000	Barrier - Control board - Arm from 2 to 4 mt	€ 1.936,00



PZ. PALLET
800x1200x1200 | 6 pz. 340 KG

- For better radio reception we recommend the use of an external aerial code 210/1

EXTRA ACCESSORIES



COD. 121854 - /1/2/3/4
Round arm, Ø 80mm



COD. 242
Fixed rod support



COD. 141
Mobile amortized rod support



COD. 121110
Fixing plate



COD. 142
Mobile curtain

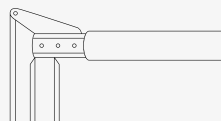

COD. SN01
Articulated rod kit



COD. 150/8038
Shockproof mechanical protection



COD. LD10
Round arm LED



COD. 124512
Reflective stickers

CODE	MODEL	DESCRIPTION	PRICE
121854	AT2	Round arm, Ø 80 mm - 2 mt	€ 135,00
121854/1	AT3	Round arm, Ø 80 mm - 3 mt	€ 195,00
121854/2	AT4	Round arm, Ø 80 mm - 4 mt	€ 261,00
121854/3	AT5	Round arm, Ø 80 mm - 5 mt	€ 325,00
121854/4	AT6	Round arm, Ø 80 mm - 6 mt	€ 351,00
SN01	SND	Articulated rod kit	€ 458,00
12478	GIU	Joint for round arm	€ 35,00
121110	CPT	Fixing plate	€ 41,00
242	SUPP	Fixed rod support	€ 87,00
141	AST	Mobile amortized rod support	€ 73,00
142	SIE	Mobile curtain - 2 mt	€ 119,00
LD10	LED - T	1 LED for round arm	€ 35,00
CL001	LD - CR	Multivoltage LED flashing circuit	€ 35,00
124512	ACTR	Reflective stickers (pack of 6 pcs)	€ 18,00
K009	BAT - B	24V Bev / Berta battery kit	€ 111,00
150/8038	PRT	Shockproof mechanical protection	€ 229,00

KIT LED recommended 1 per meter of the arm

LED FLASHER CIRCUIT steady light - sequential / rotating flashing

BEV 2

ELECTROMECHANICAL BARRIER 230V - 24V

i ARMS UP TO 6 MT



INSTRUCTIONS



RESIDENTIAL



COLLECTIVE



POWER SUPPLY 230V - 24V



IRREVERSIBLE

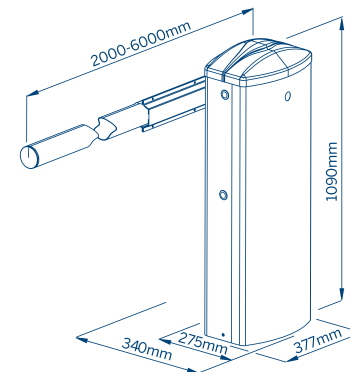

FEATURES

- Irreversible, intensive use
- Stainless steel structure
- Motor box in cast aluminum
- Steel and cast iron gears
- High Performance electric motor
- Mechanical parts lubricated with lithium grease
- Opening and closing microswitches
- Opening and closing microswitches
- Round arm standard - Rectangular arm optional
- Mechanical release with key
- Arm length max 6 mt / arm kit LED (optional)
- Pre-wiring and easy programming software
- Control board with built-in receiver and antenna
- Anti-squashing system * (EN 12453)
- Slowing down function * (EN 12453)
- Electronic torque control
- Anti black out battery kit

* Functions guaranteed with VDS electronics devices

PERFORMANCE REQUIREMENTS

- Operating Cycle SEMI-INTENSIVE 230V, INTENSIVE 24V
- Use frequency 50% (230VAC) - 100% (24VCC)
- Opening time 10 SEC

TECHNICAL FEATURES

	BEV 2 230	BEV 2 24
Power supply	230VAC	24VCC
Max length arm	6 MT	6 MT
Opening time	10 SEC	10 SEC
Absorbed power	250 W	60 W
Motor weight	45 KG	45 KG
Noise level	< 30 DBA	< 30 DBA
Enviromental conditions	-20 / +55° C	-20 / +55° C
Protection degree	IP44	IP44

BARRIERS

CODE	MODEL	DESCRIPTION	PRICE
1432/V	BEV 2 230V	Barrier - Control board - Arm from 3 to 6 mt	€ 2.233,00
1432/2V	BEV 2 230V FAST	Barrier - Control board - Arm from 2 to 4 mt	€ 2.233,00
1428/V	BEV 2 24V	Barrier - Control board - Arm from 3 to 6 mt	€ 2.290,00
1428/3V	BEV 2 24V FAST	Barrier - Control board - Arm from 2 to 4 mt	€ 2.290,00



PZ. PALLET
800x1200x1200 | 6 pz. 360 KG

• For better radio reception we recommend the use of an external aerial code 210/1

EXTRA ACCESSORIES



COD. 121854 - /1/2/3/4
Round arm, Ø 80mm



COD. 242
Fixed rod support

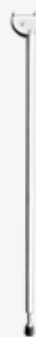

COD. 141
Mobile amortized rod support



COD. 121110
Fixing plate



COD. 142
Mobile curtain

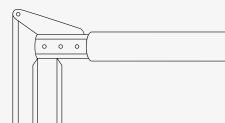

COD. SN01
Articulated rod kit



COD. 150/8038
Shockproof mechanical protection



COD. LD10
Round arm LED



COD. 124512
Reflective stickers

CODE	MODEL	DESCRIPTION	PRICE
121854	AT2	Round arm, Ø 80 mm - 2 mt	€ 135,00
121854/1	AT3	Round arm, Ø 80 mm - 3 mt	€ 195,00
121854/2	AT4	Round arm, Ø 80 mm - 4 mt	€ 261,00
121854/3	AT5	Round arm, Ø 80 mm - 5 mt	€ 325,00
121854/4	AT6	Round arm, Ø 80 mm - 6 mt	€ 351,00
SN01	SND	Articulated rod kit	€ 458,00
12478	GIU	Joint for round arm	€ 35,00
121110	CPT	Fixing plate	€ 73,00
242	SUPP	Fixed rod support	€ 87,00
141	AST	Mobile amortized rod support	€ 73,00
142	SIE	Mobile curtain - 2 mt	€ 119,00
LD10	LED - T	1 LED for round arm	€ 35,00
CL001	LD - CR	Multivoltage LED flashing circuit	€ 35,00
124512	ACTR	Reflective stickers (pack of 6 pcs)	€ 18,00
K009	BAT - B	24V Bev / Berta battery kit	€ 111,00
150/8038	PRT	Shockproof mechanical protection	€ 229,00

KIT LED recommended 1 per meter of the arm

LED FLASHER CIRCUIT steady light - sequential / rotating flashing

Automations for Road Barriers

BERTA MANUALE BARRIER

i ARMS UP TO 6 MT



INSTRUCTIONS



RESIDENTIAL



COLLECTIVE

FEATURES

- Powder coated steel structure
- Motor box in cast aluminum
- Steel and cast iron gears
- Mechanical parts lubricated with lithium grease
- Round arm standard
- Crank release
- Arm length max 6 mt

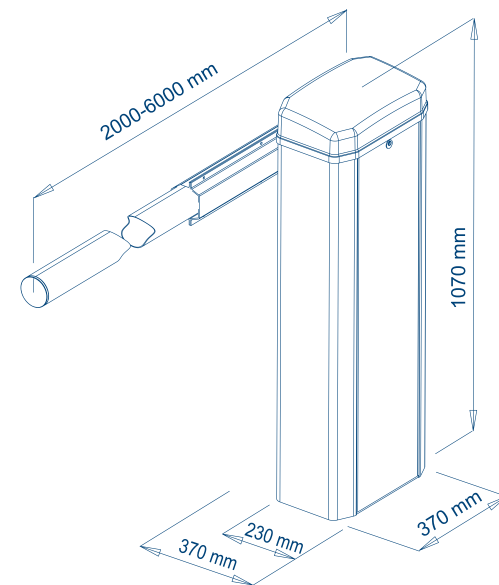

BARRIERS

CODE	MODEL	DESCRIPTION	PRICE
1440	BERTA-M	Manual barrier - Arm from 2 to 4 mt	€ 1.580,00



PZ. PALLET
800x1200x1200 | 6 pz. 340 KG

EXTRA ACCESSORIES



COD. 121854 - /1/2
Round arm, Ø 80mm



COD. 242
Fixed rod support

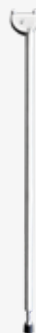

COD. 141
Mobile amortized rod support



COD. 121110
Fixing plate



COD. 142
Mobile curtain



COD. 150/8038
Shockproof mechanical protection



COD. LD10
Round arm LED



COD. 124512
Reflective stickers

CODE	MODEL	DESCRIPTION	PRICE
121854	AT2	Round arm, Ø 80 mm - 2 mt	€ 135,00
121854/1	AT3	Round arm, Ø 80 mm - 3 mt	€ 195,00
121854/2	AT4	Round arm, Ø 80 mm - 4 mt	€ 261,00
121854/3	AT5	Round arm, Ø 80 mm - 5 mt	€ 325,00
121854/4	AT6	Round arm, Ø 80 mm - 6 mt	€ 351,00
12478	GIU	Joint for round arm	€ 35,00
121110	CPT	Fixing plate	€ 41,00
242	SUPP	Fixed rod support	€ 87,00
141	AST	Mobile amortized rod support	€ 73,00
142	SIE	Mobile curtain - 2 mt	€ 119,00
124512	ACTR	Reflective stickers (pack of 6 pcs)	€ 18,00
150/8038	PRT	Shockproof mechanical protection	€ 229,00

KIT LED recommended 1 per meter of the arm

LED FLASHER CIRCUIT steady light - sequential / rotating flashing

The background consists of a solid blue field with a large, bright orange triangular shape on the left side, pointing towards the top-left corner.

TRAFFIC **BOLLARDS**

MOLE

VERTICAL HYDRAULIC BOLLARD 230V



INSTRUCTIONS

 POWER SUPPLY 230V

 IRREVERSIBLE

 HYDRAULIC

FEATURES

- Inner pillar in 4 mm thick steel
- Outer pillar (foundation case) in galvanized steel
- The automation does not need any adjustment and calibration, and this characterizes its immediate installation for proper operation
- The movement of the pillar ends automatically with the increase in the absorption of the electric motor
- The manual release takes place by acting on the upper part of the pylon with a triangular key
- The LED luminous flux visible at 360°, both with the mast lowered and raised, and the retro-reflective film guarantees perfect visibility of the bollard
- The fluidity of the pylon movement is ensured by an electromechanical system with epicyclic reduction in a watertight aluminum casing
- The control unit manages the movement ensuring maximum safety and constant performance over time

PERFORMANCE REQUIREMENTS

- Operating Cycle **INTENSIVE**
- Use frequency **100%**
- Opening time **4,5 SEC**
- Closing time **2 SEC**

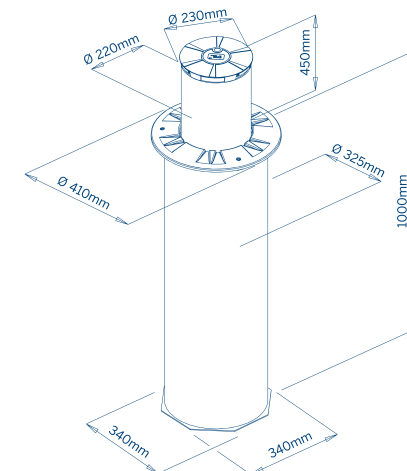

BOLLARDS

CODE	MODEL	DESCRIPTION	PRICE
2001/1	MOLE	Hydraulic bollard - Control board	€ 4.580,00
2001/3	MOLE-F	Fixed bollard	€ 3.548,00



PZ. PALLET
800x120x130 | 3 pz. 400 KG

- For better radio reception we recommend the use of an external aerial code 210/1.
- In presence of strong cold temperatures, the performance of the actuator can be significantly reduced

EXTRA ACCESSORIES



COD. E102/P
E102 control board with
bollard software + receiver



COD. 12/C
Pair of photocells



COD. 23/8
LED flashing light



COD. 23/4
Wall fixing base



COD. E010
Remote control



COD. 165B
Warning sign



ALZO

CHAIN BARRIER

i PASSAGES UP TO 20 MT



INSTRUCTIONS



RESIDENTIAL



COLLECTIVE



POWER SUPPLY 230V - 24V



IRREVERSIBLE

FEATURES

- Chain barrier to easily delimit small parkings or driveways
- Quick and easy installation
- Smart: thanks to obstacle detection and automatic stroke programming
- Always ready: operation in absence of current with rechargeable batteries that can be connected to the control board via the battery charger card, through a comfortable guided coupling connector
- Chain up to 20 mt in length
- Galvanized and painted steel structure
- It does not require maintenance and thanks to the magnetic loop you can improve the degree of automation of your application

TECHNICAL FEATURES

Power supply	230VAC – 50HZ
Power supply	24 VDC
Average absorption	1.0
Absorbed power	24
Max chain length	20
Motor weight	16
Column height	1010
Service	50
Protection degree	34
Control unit	ACTION

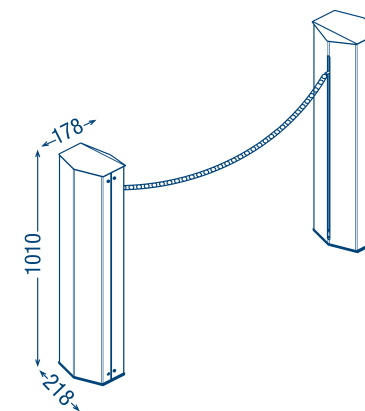

OPERATORS

CODE	MODEL	DESCRIPTION	PREZZO
12007374	ALZ-M	Operator 24V with encoder - Built-in ACTION control board with slowdowns in opening and closing - Column height 1010 mm	€ 1.417,00
12007379	ALZ-S	Operator 24V - Column height 1010 mm	€ 1.030,00



PZ. PALLET
800x1200x1200 | 6 pz. 340 KG

EXTRA ACCESSORIES



COD. 64000404
Two-tone white and red steel chain

€ 22,00 (price per mt)



COD. 64000405
Steel and galvanized chain

€ 22,00 (price per mt)



COD. 12007395
Breakout joint

€ 42,00



COD. 64000409
Recessed guide in galvanized sheet 2 mt

€ 62,00



COD. 61700406
M8x25 turned stainless steel screw

€ 11,00



COD. 64000407
Ø 6 mm stainless steel junction mesh

€ 29,00



COD. 12000780
24V plug-in battery charger with electronic charge control

€ 32,00



COD. 12000757
Batteries kit in box 2 batteries 1.3 Ah - 1 mt cable

€ 129,00



COD. 420
12V 7 Ah rechargeable battery - 2 batteries required

€ 50,00



COD. 12666482
433 mHz plug-in receiver - 1 channel - with antenna

€ 97,00

The background consists of a solid blue field with a large orange triangle on the left side, pointing towards the top right corner.

AUTOMATIONS FOR **ROLLING SHUTTERS**

TONDO

OPERATOR FOR SHUTTERS

i WEIGHT UP TO 180 KG



INSTRUCTIONS

 RESIDENTIAL

 COLLECTIVE

 POWER SUPPLY 230V

 IRREVERSIBLE

FEATURES

- New design
- Quick installation even on existing shutters
- Irreversible
- Manual release
- Electric brake
- Mechanical limit switch built-in, easy adjustable
- Fast, reliable and silent
- Power supply 230V

PERFORMANCE REQUIREMENTS

MODELS	A	B	C
TONDO 140	60/48 MM	200/220 MM	320 MM
TONDO 180	60/48 MM	200/220 MM	320 MM



TECHNICAL FEATURES

	TONDO 140	TONDO 180
Power supply	230VAC	230VAC
Lifting force	140 KG	180 KG
Condenser	18 UF	22 UF
Average absorption	2,5 A	2,5 A
Absorbed power	520 W	700 W
RPM ring	9 / MIN	9 / MIN
Motor weight	8 KG	10 KG
Enviromental conditions	-20 / +85° C	-20 / +85° C
Limit switch	6 MT	6 MT

OPERATORS AND ACCESSORIES

CODE	MODEL	DESCRIPTION	PRICE
1000043/R	TONDO 140	140 kg Shutter operator with electric brake - Ø 48-60	€ 275,00
1000043/B	TONDO 180	180 kg Shutter operator with electric brake - Ø 48-60	€ 299,00
RD33	AD 33	33 mm adapter - 1 pair	€ 29,00
RD42	AD 42	42 mm adapter - 1 pair	€ 29,00
RD48	AD 48	48 mm adapter - 1 pair	€ 29,00
43364/050	ELT TONDO	Electric brake with release cable	€ 59,00

 PZ. PALLET
800x1200x1300 | 50 pz. 520 KG

- For better radio reception we recommend the use of an external aerial code 210/1
- In presence of strong cold temperatures, the performance of the actuator can be significantly reduced

EXTRA ACCESSORIES



COD. S-0215-01
Control board with built-in receiver and antenna



COD. 12/C
Pair of photocells



COD. 23/8
LED flashing light



COD. 23/4
Wall fixing base



COD. 198/5
Key selector



COD. E010
Remote control



COD. 165B
Warning sign



COD. 854/1
Blindino selector



COD. 93370000
Control board for the control of 2 dead-man motors - without receiver



COD. 93330000
Control board for the control of 4 dead-man motors - without receiver



COD. 96050000
Control board with low voltage dead-man controls - without receiver

ROLL OPERATOR FOR SHUTTERS

i WEIGHT UP TO 300 KG



INSTRUCTIONS

RESIDENTIAL

COLLECTIVE

POWER SUPPLY 230V

REVERSIBLE

IRREVERSIBLE

FEATURES

- New design
- Quick installation even on existing shutters
- Irreversible
- Manual release
- Electric brake
- Mechanical limit switch built-in, easy adjustable
- Fast, reliable and silent
- Power supply 230V



PERFORMANCE REQUIREMENTS

MODELS	A	B	C
ROLL 200 150 KG	60/48 MM	200/220 MM	320 MM
ROLL 200/2M 300 KG	60/48 MM	200/220 MM	320 MM
ROLL 240 170 KG	76/101 MM	240 MM	320 MM
ROLL 240/2M 300 KG	76/101 MM	240 MM	320 MM

TECHNICAL FEATURES

	ROLL 200	ROLL 240	ROLL 200-2 M	ROLL 240-2 M
Power supply	230VAC	230VAC	230VAC	230VAC
Lifting force	150 KG	170 KG	300 KG	300 KG
Condenser	16 UF	20 UF	35 UF	40 UF
Average absorption	2 A	2,8 A	2X2,8 A	2X2,8 A
Absorbed power	400 W	600 W	2X600 W	2X600 W
RPM ring	9 / MIN	8 / MIN	8 / MIN	8 / MIN
Motor weight	8 KG	9 KG	11 KG	13 KG
Enviromental conditions	-20 / +85° C	-20 / +85° C	-20 / +85° C	-20 / +85° C
Limit switch	7 / 8 MT	7 / 8 MT	7 / 8 MT	7 / 8 MT

OPERATORS AND ACCESSORIES

CODE	MODEL	DESCRIPTION	PRICE
1000043	ROLL 200	150 kg Shutter operator - Ø 48-60 - Without electric brake	€ 255,00
100099/5	ROLL 240	170 kg Shutter operator with electric brake - Ø 76-101	€ 572,00
100099/6	ROLL 240 - 2M	300 kg Double shutter operator with electric brake - Ø 76 - 101	€ 859,00
100099/7	ROLL 200 - 2M	300 kg Double shutter operator with electric brake - Ø 48 - 60 mm	€ 859,00
RD33	AD 33	adapter - 1 pair	€ 29,00
RD42	AD 42	42 mm adapter - 1 pair	€ 29,00
RD48	AD 48	48 mm adapter - 1 pair	€ 29,00
1000043/1	ELT	Electric brake with release cable	€ 59,00



PZ. PALLET
800x1200x1300 | 50 pz. 520 KG

- For better radio reception we recommend the use of an external aerial code 210/1
- In presence of strong cold temperatures, the performance of the actuator can be significantly reduced

EXTRA ACCESSORIES



COD. S-0215-01
Control board with built-in receiver and aerial



COD. 12/C
Pair of photocells



COD. 23/8
LED flashing light



COD. 23/4
Wall fixing base



COD. 198/5
Key selector



COD. E010
Remote control



COD. 165B
Warning sign



COD. 854/1
Blindino selector



COD. 93370000
Control board for the control of 2 dead-man motors - without receiver



COD. 93330000
Control board for the control of 4 dead-man motors - without receiver



COD. 96050000
Control board with low voltage dead-man controls - without receiver



COD. 1000043/1
Electric brake with release



AUTOMATIONS FOR
SHUTTERS AND AWINGS

Automations for Shutters and Awings

KINDI

AUTOMATION FOR SHUTTERS

i WEIGHT UP TO 139 KG



CODE	MODEL	DESCRIPTION	PRICE
12365	KINDI 20 NM	Tubular motor - Shutters up to 36 kg - Bracket and adapter 60 mm	€ 143,00
12458	KINDI 30 NM	Tubular motor - Shutters up to 56 kg - Bracket and adapter 60 mm	€ 154,00
125648	KINDI 50 NM	Tubular motor - Shutters up to 90 kg - Bracket and adapter 60 mm	€ 172,00
125655	KINDI 100 NM	Tubular motor - Shutters up to 139 kg - Minimum bracket and adapter	€ 389,00



RESIDENTIAL

POWER SUPPLY 230V

INSTRUCTIONS

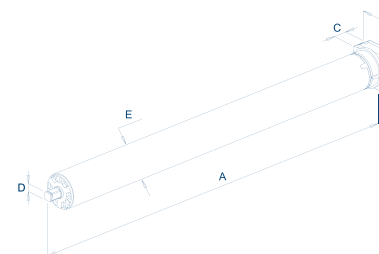

PERFORMANCE REQUIREMENTS

- Operator in cast aluminum painted
- New design
- Mechanical limit switch
- Speed, silence and reliability
- Bracket and adapter 60/70 mm
- Wide range of adapters and accessories
- Extra 5 year warranty
- Power supply 230V
- Motor weight 3 kg

TECHNICAL FEATURES

	A	B	C	D	E
KINDI 20	456 MM	55 MM	17 MM	10X10 MM □	45 MM Ø
KINDI 30	536 MM	55 MM	17 MM	10X10 MM □	45 MM Ø
KINDI 50	536 MM	55 MM	17 MM	10X10 MM □	45 MM Ø
KINDI 100	660 MM	70 MM	21 MM	30 MM Ø ○	60 MM Ø



PZ. PALLET
800x1200x1200 | 80 pz. 320 KG

Automations for Shutters and Awings

KENDA

AUTOMATION WITH EMERGENCY MANEUVER

i WEIGHT UP TO 139 KG

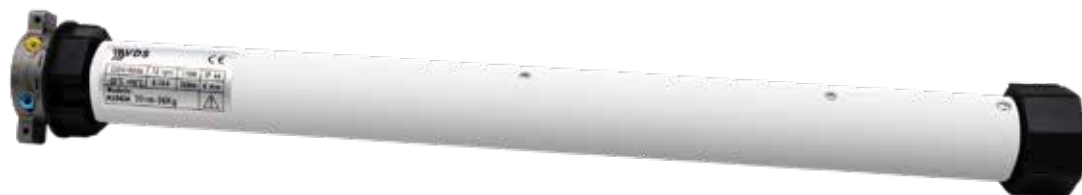

 RESIDENTIAL

 POWER SUPPLY 230V

INSTRUCTIONS

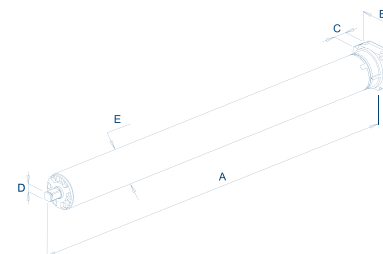

PERFORMANCE REQUIREMENTS

- Operator in cast aluminum painted
- New design
- Mechanical limit switch
- Speed, silence and reliability
- Bracket and adapter 60/70 mm
- Wide range of adapters and accessories
- Extra 5 year warranty
- Power supply 230V
- Motor weight 3 kg

TECHNICAL FEATURES

	A	B	C	D	E
KENDA 50	660 MM	70 MM	21 MM	30 MM	□ 45 MM Ø
KENDA 100	700 MM	100 MM	28 MM	10X10 MM Ø	○ 60 MM Ø

CODE	MODEL	DESCRIPTION	PRICE
43000/90	KENDA 50 NM	Tubular motor - With maneuver - Curtains up to 90 kg	€ 241,00
125656	KENDA 100 NM	Tubular motor - With maneuver - Curtains up to 139 kg - Minimum adapter 70 mm	€ 413,00



PZ. PALLET
800x1200x1200 | 80 pz. 320 KG

ACCESSORIES FOR SHUTTERS



CODE	DESCRIPTION	PRICE
AM5196	Control board - 230V - With radio receiver	€ 103,00



CODE	DESCRIPTION	PRICE
1610111-MA1	Roller shutter module for single commands - Without receiver	€ 58,00



CODE	DESCRIPTION	PRICE
PROXMINI	Control board - 230V - With radio receiver	€ 80,00



CODE	DESCRIPTION	PRICE
93330000	Control unit for the control of 4 motors to man present - Without receiver	€ 212,00



CODE	DESCRIPTION	PRICE
AM5154	Remote control - 6 channels - With display	€ 81,00
AM5189	Remote control - 12 channels - With display	€ 88,00



CODE	DESCRIPTION	PRICE
93370000	Control unit for the control of 2 motors to man present - Without receiver	€ 70,00

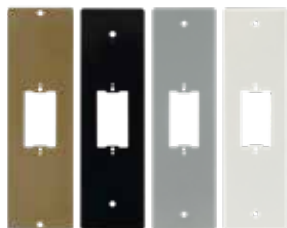

CODE	DESCRIPTION	PRICE
PLA142B	Plate with hole for button - Center distance 142 Bronze	€ 46,00
PLA142G	Plate with hole for button - Center distance 142 Grey	€ 46,00
PLA142W	Plate with hole for button - Center distance 142 White	€ 46,00
PLA142N	Plate with hole for button - Center distance 142 Black	€ 46,00
PLA165B	Plate with hole for button - Center distance 165 Bronze	€ 46,00
PLA165G	Plate with hole for button - Center distance 165 Grey	€ 46,00
PLA165W	Plate with hole for button - Center distance 165 White	€ 46,00
PLA165N	Plate with hole for button - Center distance 165 Black	€ 46,00
PLA185B	Plate with hole for button - Center distance 185 Bronze	€ 46,00
PLA185G	Plate with hole for button - Center distance 185 Grey	€ 46,00
PLA185W	Plate with hole for button - Center distance 185 White	€ 46,00
PLA185N	Plate with hole for button - Center distance 185 Black	€ 46,00
PLA205B	Plate with hole for button - Center distance 205 Bronze	€ 46,00
PLA205G	Plate with hole for button - Center distance 205 Grey	€ 46,00
PLA205W	Plate with hole for button - Center distance 205 White	€ 46,00
PLA205N	Plate with hole for button - Center distance 205 Black	€ 46,00

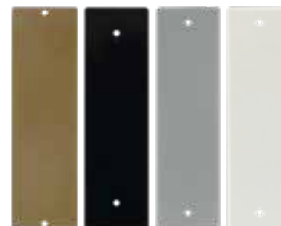

CODE	DESCRIPTION	PRICE
PLA142B/C	Blind plate with center distance 142 Bronze	€ 44,00
PLA142G/C	Blind plate with center distance 142 Grey	€ 44,00
PLA142W/C	Blind plate with center distance 142 White	€ 44,00
PLA142N/C	Blind plate with center distance 142 Black	€ 44,00
PLA165B/C	Blind plate with center distance 165 Bronze	€ 44,00
PLA165G/C	Blind plate with center distance 165 Grey	€ 44,00
PLA165W/C	Blind plate with center distance 165 White	€ 44,00
PLA165N/C	Blind plate with center distance 165 Black	€ 44,00
PLA185B/C	Blind plate with center distance 185 Bronze	€ 44,00
PLA185G/C	Blind plate with center distance 185 Grey	€ 44,00
PLA185W/C	Blind plate with center distance 185 White	€ 44,00
PLA185N/C	Blind plate with center distance 185 Black	€ 44,00
PLA205B/C	Blind plate with center distance 205 Bronze	€ 44,00
PLA205G/C	Blind plate with center distance 205 Grey	€ 44,00
PLA205W/C	Blind plate with center distance 205 White	€ 44,00
PLA205N/C	Blind plate with center distance 205 Black	€ 44,00



CODE	DESCRIPTION	PRICE
INT001	Up-down button with support	€ 28,00

Automations for Shutters and Awings | **Accessories for Shutters**

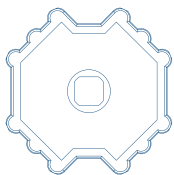

CODE	DESCRIPTION	PRICE
43380/156	Octagonal for roller Ø 60 mm	€ 14,00

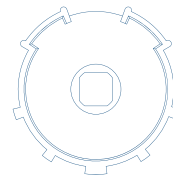

CODE	DESCRIPTION	PRICE
43380/060	ZF 54	€ 14,00

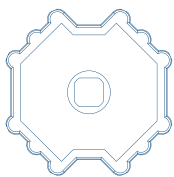

CODE	DESCRIPTION	PRICE
43380/061	Octagonal for roller Ø 70 mm	€ 14,00

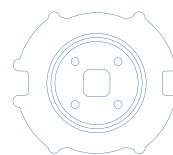

CODE	DESCRIPTION	PRICE
43380/062	ZF 64	€ 14,00

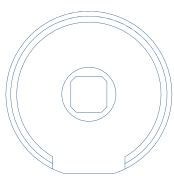

CODE	DESCRIPTION	PRICE
43380/063	Round for roller Ø 50 mm	€ 14,00

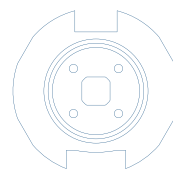

CODE	DESCRIPTION	PRICE
43380/065	DEPRAT 62	€ 14,00

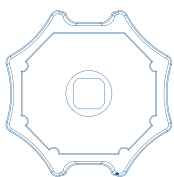

CODE	DESCRIPTION	PRICE
43380/058	Bonfanti - Gaviota	€ 14,00

Automations for Shutters and Awings | **Accessories for Shutters**



CODE	DESCRIPTION	PRICE
43380/110	Adjustable support	€ 24,00



CODE	DESCRIPTION	PRICE
140MKA	Articulated maneuver rod with hook	€ 97,00



CODE	DESCRIPTION	PRICE
43380/111	Wall support	€ 24,00



CODE	DESCRIPTION	PRICE
43380/057	Adjustable support	€ 24,00



CODE	DESCRIPTION	PRICE
43380/102	Bracket for box one-position	€ 18,00
43380/101	Bracket for box two-position	€ 18,00



CODE	DESCRIPTION	PRICE
43380/068	Support with release	€ 24,00



CODE	DESCRIPTION	PRICE
43380/116	Hexagonal eyelet kit 7 mm	€ 18,00



CODE	DESCRIPTION	PRICE
43380/109	Flat support square pin	€ 18,00



CODE	MODEL	DESCRIPTION	PRICE
G41CF	CAL	Galvanized cap Ø 60 mm	€ 14,00



CODE	MODEL	DESCRIPTION	PRICE
GU68CU	SU-CU	Support with bearing	€ 14,00



CODE	MODEL	DESCRIPTION	PRICE
G42CP	CAL-PV7	PVC cap Ø 70 mm	€ 14,00
777/4	CAL-PV6	PVC cap Ø 60 mm	€ 14,00

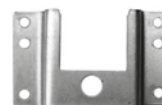

CODE	MODEL	DESCRIPTION	PRICE
777/11	STAF-P	Wall bracket	€ 24,00



CODE	MODEL	DESCRIPTION	PRICE
AI70-1	CAL-R7	Adjustable cap Ø 70 mm	€ 24,00
AI60-3	CAL-R6	Adjustable cap Ø 60 mm	€ 24,00



CODE	MODEL	DESCRIPTION	PRICE
777/12	CU-ST	Bearing for wall bracket	€ 22,00



CODE	MODEL	DESCRIPTION	PRICE
GA3R608/1	RU1	Octagonal roller Ø 60 - 1000 mm	€ 32,00
GA3R608/1.5	RU15	Octagonal roller Ø 60 - 1500 mm	€ 52,00
GA3R608/2	RU2	Octagonal roller Ø 60 - 2000 mm	€ 67,00
GA3R70/2	RU2-7	Octagonal roller Ø 70 - 2000 mm	€ 75,00
GA370/3	RU3-7	Octagonal roller Ø 70 - 3000 mm	€ 112,00



CODE	MODEL	DESCRIPTION	PRICE
1098/DS	TES	Motor head	€ 24,00

Automations for Shutters and Awings | **Accessories for Shutters**



CODE	MODEL	DESCRIPTION	PRICE
G62CU	ST-CUS	Bracket with bearing	€ 24,00



CODE	MODEL	DESCRIPTION	PRICE
GA8S70	BLC-T	Shutter lock Ø 70 mm	€ 35,00



CODE	MODEL	DESCRIPTION	PRICE
777/20	ZNC	Wall support	€ 24,00



CODE	MODEL	DESCRIPTION	PRICE
GA8S60/4	BLC-T	Shutter lock Ø 60 mm	€ 35,00



CODE	MODEL	DESCRIPTION	PRICE
777/15	GAZ	Galvanized hook	€ 24,00



CODE	MODEL	DESCRIPTION	PRICE
777/18	DLC-T	Shutter lock	€ 35,00



CODE	MODEL	DESCRIPTION	PRICE
VS178/F	178	Anti-scratch attachment spring	€ 24,00



CODE	MODEL	DESCRIPTION	PRICE
777/19	ANL	Ring Ø 60 mm for shutter block	€ 24,00

ACCESSORIES FOR AWINGS

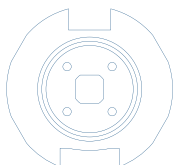

CODE	DESCRIPTION	PRICE
TECH/VS005/C	Warhead for tube Ø 60 mm	€ 19,00



CODE	DESCRIPTION	PRICE
71600	Warhead for tube Ø 70 mm - Thickness 10/10	€ 14,00 per mt

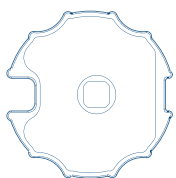

CODE	DESCRIPTION	PRICE
43380/064	Warhead for tube Ø 70 mm	€ 14,00



CODE	DESCRIPTION	PRICE
81600	Warhead for tube Ø 78 mm - Thickness 10/10	€ 14,00 per mt

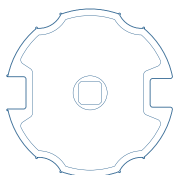

CODE	DESCRIPTION	PRICE
43380/059	Warhead for tube Ø 78 mm	€ 14,00



CODE	DESCRIPTION	PRICE
14035	Adjustable ogive cap Ø 70 mm	€ 24,00
15035	Adjustable ogive cap Ø 78 mm	€ 24,00



CODE	DESCRIPTION	PRICE
14001	Ogive cap Ø 70 mm	€ 24,00
18001	Ogive cap Ø 78 mm	€ 24,00

Automations for Shutters and Awings | **Accessories for Awings**



CODE	DESCRIPTION	PRICE
74	Wind speed detector	€ 75,00



CODE	DESCRIPTION	PRICE
76	Control board - 230V - With radio receiver - With box	€ 207,00



CODE	DESCRIPTION	PRICE
RA	Ambient light detector	€ 96,00



CODE	DESCRIPTION	PRICE
AM5154	Remote control - 6 channels - With display	€ 81,00
AM5189	Remote control - 12 channels - With display	€ 88,00



CODE	DESCRIPTION	PRICE
RS	Rain detector	€ 138,00



CODE	DESCRIPTION	PRICE
93370000	Control unit for the control of 2 motors to man present - Without receiver	€ 70,00



CODE	DESCRIPTION	PRICE
96800000	Electronic control board with anemometer and sun sensor - With radio receiver	€ 258,00



CODE	DESCRIPTION	PRICE
93070000	Individual or centralized control board for 4 motors with inputs for wind, sun, rain sensors - Without receiver	€ 258,00



CODE	DESCRIPTION	PRICE
96860000	Electronic control board with anemometer, rain sensor and sun sensor - With radio receiver	€ 304,00



CODE	DESCRIPTION	PRICE
93330000	Control unit for the control of 4 motors to man present - Without receiver	€ 212,00



CODE	DESCRIPTION	PRICE
91710005	1 channel remote control	€ 70,00
91720005	3 channels remote control	€ 87,00
91730005	6 channels remote control	€ 92,00

ACCESSORIES FOR
SKYLIGHTS, WINDOWS, DOMES

MICRO EVO 1

CHAIN OPERATOR



INSTRUCTIONS



RESIDENTIAL



POWER SUPPLY 230V



FEATURES

- Linear electric operator with double link articulated chain contained within a metal casing
- Equipped with overload protection system and automatic limit switch adjustment in closing
- It has 4 types of electronically selectable strokes
- Equipped with a synchronization system capable of coordinating the movement of the chain of several operators (up to 4) without the need for any external control board
- Complete with accessories for installation on hinged windows or vasistas
- Possibility of adjusting the stroke by means of a selector
- Soft stop closure to preserve the window
- Reduced height: 35 mm

TECHNICAL FEATURES

Power	MAX THRUST 300N
Voltage	110-240V / 24V
Power	110-240V AC: 25W / 24V DC: 24W
Stroke selectable	100 - 200 - 300 - 400
Limit switch opening and closing	ELECTRONIC
Protection degree	IP32
Minimum speed	CA. 13 MM/S
Operating temperature	-10° C + 40° C
Certifications	CE - VDE

OPERATORS

CODE	DESCRIPTION	COLOR	THRUST	POWER	PROTECTION DEGREE	MINIMUM SPEED	PRICE
2713789	MICRO EVO1 - 230V	Silver	300 N	25 W	IP32	13 mm/s	€ 447,00
2713790	MICRO EVO1 - 230V	Black RAL 9005	300 N	25 W	IP32	13 mm/s	€ 447,00
2713791	MICRO EVO1 - 230V	White RAL 9003	300 N	25 W	IP32	13 mm/s	€ 447,00
2713792	MICRO EVO1 - 24V	Silver	300 N	24 W	IP32	13 mm/s	€ 455,00
2713793	MICRO EVO1 - 24V	Black RAL 9005	300 N	24 W	IP32	13 mm/s	€ 455,00
2713794	MICRO EVO1 - 24V	White RAL 9003	300 N	24 W	IP32	13 mm/s	€ 455,00



PZ. PALLET
800x1200x1200 | 80 pz. 320 KG

Accessories for Skylights, Windows, Domes

D8 FCE ROD OPERATOR



INSTRUCTIONS



RESIDENTIAL



POWER SUPPLY 230V



FEATURES

- Rigid rod linear electric operator with high resistance to peak loads
- Operation with 230V AC 50Hz power supply
- Compliant with the relevant European Directives
- Equipped with limit switches and relays for parallel connection
- Built-in thermal protection
- Available color: silver anodized
- Complete with fixing accessories

TECHNICAL FEATURES

Power	MAX THRUST 300N-TRACTION: MAX 300N
Voltage	230V AC 50HZ
Limit switch opening and closing	MICROSWITCH
Protection degree	IP55
Operating temperature	-10° C + 60° C
Cable	PVC BLACK
Certifications	CE - VDE

OPERATORS

CODE	MODEL	DESCRIPTION	PRICE
2700292	D8-200	D8 Fce - 200 mm - 500 N - 175 W - IP55 - Silver	€ 289,00
2700293	D8-300	D8 Fce - 300 mm - 500 N - 175 W - IP55 - Silver	€ 310,00
2700297	D8-400	D8 Fce - 400 mm - 500 N - 175 W - IP55 - Silver	€ 417,00

ACCESSORIES

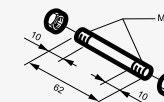

COD. 2700102
Front pin for sunshade versions
€ 11,00

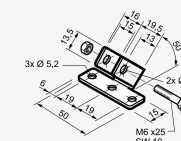

COD. 2700064
Front bracket for window frame
€ 11,00

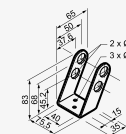

COD. 2700124
Silver actuator support bracket
€ 22,00

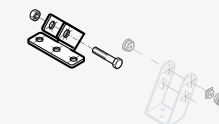

COD. 2700107
Front frame bracket + actuator bracket accessories
€ 27,00



PZ. PALLET
200 pz. 6000 KG

The background consists of a solid blue field with a large, diagonal orange shape on the left side, creating a modern, abstract design.

AUTOMATIONS FOR **SLIDING DOORS AND TURNSTILES**

RIKI-20

AUTOMATIC TURNSTILE



INSTRUCTIONS

RESIDENTIAL

COLLECTIVE

POWER SUPPLY 230V

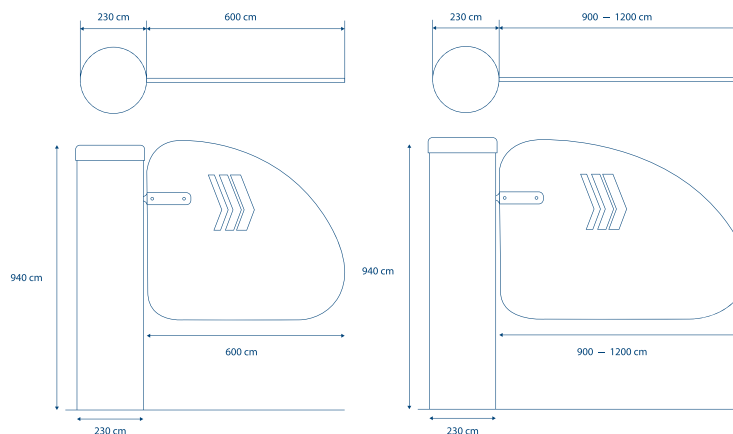

FEATURES

- AISI 304 stainless steel structure and polycarbonate leaf
- Integrated luminous crown: indicates suitability for entry and movement of the wing (red: stop - green: okay)
- Integration with access control: people counter system, temperature measurement system, detects mask. The opening of the leaf can also be activated by a card reader, by photocells or other control device
- The system can be interfaced with other automatic opening systems
- The leaf can be closed automatically or activated by device command (also via radio)
- The release maneuver can be carried out using a button or a key
- Polycarbonate leaf is available in 3 sizes 600-900-1200 mm
- The system can work with buffer batteries allowing operation even in the event of a blackout black-out. The system is equipped with an amperometric safety device controlled by an encoder: if you accidentally hit the leaf, it stops, goes back and then performs a slow maneuver to check for the absence of obstacles

TECHNICAL FEATURES

Protection degree	IP44
Power supply	120 / 230VAC
Motor power supply	24 DC
Absorption (standby)	350 MA
Power	120 W
Operating temp. (° C)	-20 / +55
Motor weight	25 KG
Opening time	2 - 3 SEC

Available with
HI-SECURITY
DEVICE

TURNSTILES

CODE	MODEL	DESCRIPTION	PRICE
RK020	RIKI20-60	Turnstile with 60 mm polycarbonate door - LED light ring	€ 4.923,00
RK020/1	RIKI20-90	Turnstile with 90 mm polycarbonate door - LED light ring	€ 5.267,00
RK020/2	RIKI20-120	Turnstile with 120 mm polycarbonate door - LED light ring	€ 5.610,00

 PZ. PALLET
4 pz. 250 KG

EXTRA ACCESSORIES



COD. RS020
Hi-Security thermal monitor



COD. RT020
Table bracket



COD. RT021
Floor bracket

CODE	MODEL	DESCRIPTION	PRICE
RS020	MONI-R	Hi-Security thermal monitor	€ 3.435,00
RT020	STAF-R	Table bracket for Hi-Security	€ 184,00
RT021	STAF-PR	Floor bracket for Hi-Security	€ 241,00

APPLICATIONS

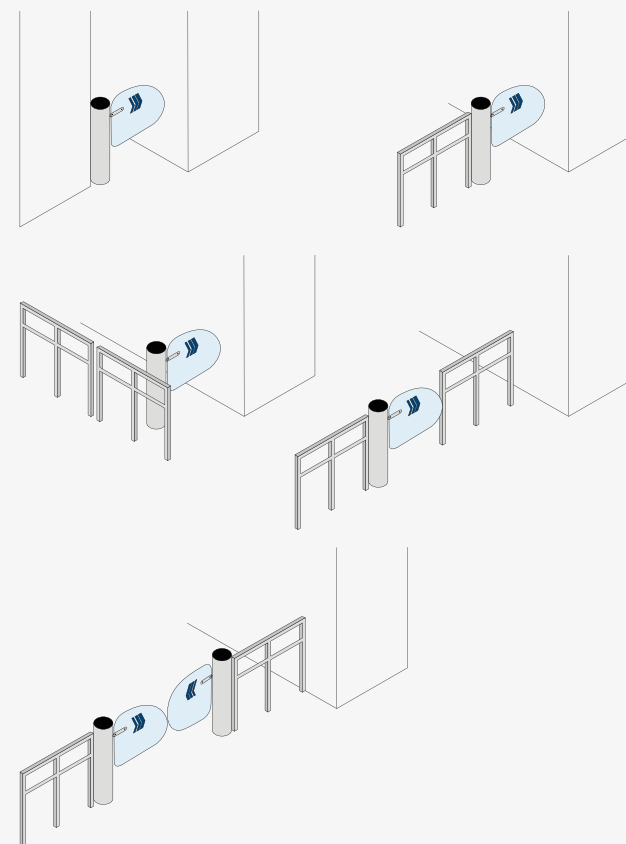

Automations for Sliding Doors and Turnstiles

SPEED PLUS

SLIDING DOOR AUTOMATION

FEATURES

- Reversible 1 motor automation for sliding doors
- Suitable for offices, supermarkets and high traffic shops
- Quick and silent movement
- Quick and easy installation
- Motor group with 100 pulses optical encoder
- Remote programming via digital selector
- Safety tests
- Interlock function
- Air curtain management



IN COMPLIANCE
WITH **EN16005**

COVERALL 1 LEAF WITH MAXIMUM WEIGHT OF 120 KG

CODE	COVERALL LENGHT (MM)	NET PASSAGE WIDTH (MM)	LEAF LENGHT (MM)	PRICE
501/1370	1370	600	700	€ 1.432,00
501/1570	1570	700	800	€ 1.445,00
501/1770	1770	800	900	€ 1.457,00
501/1970	1970	900	1000	€ 1.470,00
501/2370	2370	1100	1200	€ 1.503,00
501/2770	2770	1300	1400	€ 1.530,00
501/3170	3170	1500	1600	€ 1.581,00
501/3570	3570	1700	1800	€ 1.615,00
501/3970	3970	1900	2000	€ 1.641,00
501/4370	4370	2100	2200	€ 1.668,00
501/4770	4770	2300	2400	€ 1.708,00
501/5170	5170	2500	2600	€ 1.864,00
501/5570	5570	2700	2800	€ 1.874,00
501/5970	5970	2900	3000	€ 1.938,00



INSTRUCTIONS

COVERALL 2 LEAVES WITH MAXIMUM WEIGHT OF 80 + 80 KG

CODE	COVERALL LENGHT (MM)	NET PASSAGE WIDTH (MM)	LEAF LENGHT (MM)	PRICE
502/1720	1720	800	2 X 450	€ 1.544,00
502/1920	1920	900	2 X 500	€ 1.550,00
502/2320	2320	1100	2 X 600	€ 1.576,00
502/2720	2720	1300	2 X 700	€ 1.609,00
502/3120	3120	1500	2 X 800	€ 1.635,00
502/3520	3520	1700	2 X 900	€ 1.661,00
502/3920	3920	1900	2 X 1000	€ 1.693,00
502/4320	4320	2100	2 X 1100	€ 1.727,00
502/4720	4720	2300	2 X 1200	€ 1.754,00
502/5120	5120	2500	2 X 1300	€ 1.897,00
502/5520	5520	2700	2 X 1400	€ 1.943,00
502/5920	5920	2900	2 X 1500	€ 1.984,00

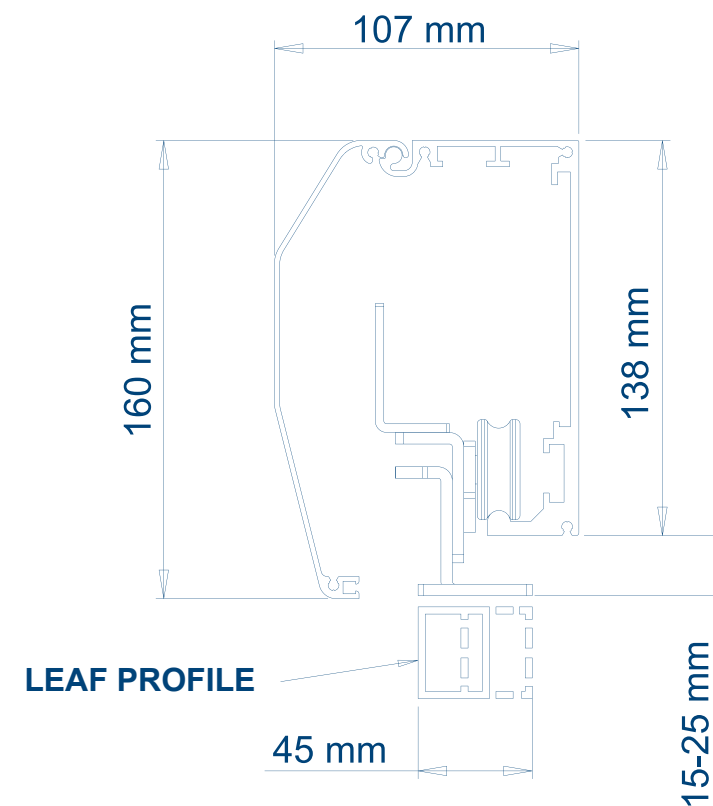

Automations for Sliding Doors and Turnstiles

GEMINI ADVANCE

SLIDING DOOR AUTOMATION

FEATURES

- Reversible 1 motor automation for sliding doors
- Suitable for offices, supermarkets and high traffic shops
- Quick and silent movement
- Quick and easy installation
- Motor group with 100 pulses optical encoder
- Remote programming via digital selector
- Safety tests
- Interlock function
- Air curtain management



IN COMPLIANCE
WITH **EN16005**

COVERALL 1 LEAF WITH MAXIMUM WEIGHT OF 150 KG

CODE	COVERALL LENGHT (MM)	NET PASSAGE WIDTH (MM)	LEAF LENGHT (MM)	PRICE
607/1370	1370	600	700	€ 1.789,00
607/1570	1570	700	800	€ 1.802,00
607/1770	1770	800	900	€ 1.809,00
607/1970	1970	900	1000	€ 1.828,00
607/2370	2370	1100	1200	€ 1.861,00
607/2770	2770	1300	1400	€ 1.887,00
607/3170	3170	1500	1600	€ 1.939,00
607/3570	3570	1700	1800	€ 1.972,00
607/3970	3970	1900	2000	€ 1.999,00
607/4370	4370	2100	2200	€ 2.026,00
607/4770	4770	2300	2400	€ 2.065,00
607/5170	5170	2500	2600	€ 2.221,00
607/5570	5570	2700	2800	€ 2.231,00
607/5970	5970	2900	3000	€ 2.295,00



INSTRUCTIONS

COVERALL 2 LEAVES WITH MAXIMUM WEIGHT OF 100 + 100 KG

CODE	COVERALL LENGHT (MM)	NET PASSAGE WIDTH (MM)	LEAF LENGHT (MM)	PRICE
608/1720	1720	800	2 X 450	€ 1.901,00
608/1920	1920	900	2 X 500	€ 1.908,00
608/2320	2320	1100	2 X 600	€ 1.933,00
608/2720	2720	1300	2 X 700	€ 1.943,00
608/3120	3120	1500	2 X 800	€ 1.992,00
608/3520	3520	1700	2 X 900	€ 2.018,00
608/3920	3920	1900	2 X 1000	€ 2.050,00
608/4320	4320	2100	2 X 1100	€ 2.084,00
608/4720	4720	2300	2 X 1200	€ 2.111,00
608/5120	5120	2500	2 X 1300	€ 2.254,00
608/5520	5520	2700	2 X 1400	€ 2.301,00
608/5920	5920	2900	2 X 1500	€ 2.341,00

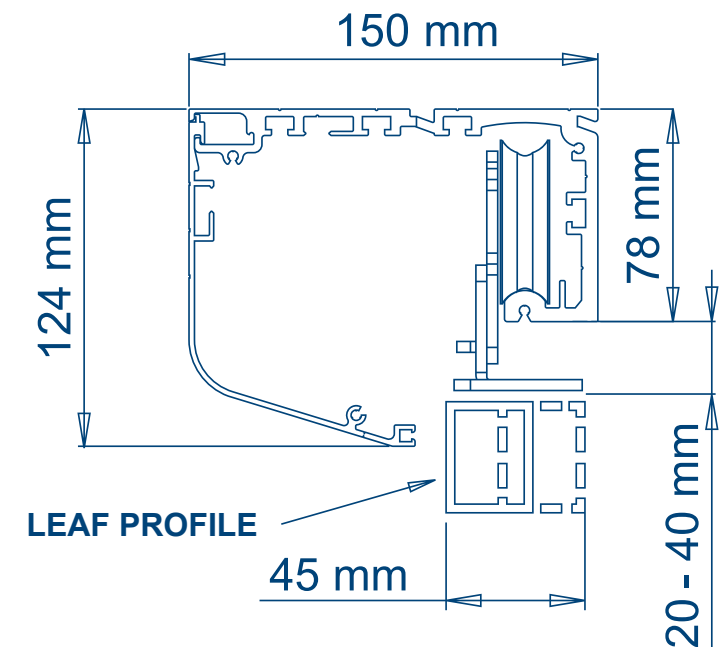

ACCESSORIES



CODE	MODEL	DESCRIPTION	PRICE
64/F	JET01	Multifunction selector with display	€ 241,00



CODE	MODEL	DESCRIPTION	PRICE
604/D	SEL	Multifunction digital touch selector	€ 218,00



CODE	MODEL	DESCRIPTION	PRICE
12/TS	TOUCH	Touch switch	€ 91,00

IDEAL FOR HOSPITALS



CODE	MODEL	DESCRIPTION	PRICE
100074/ECO	HR50-ECO	Omnidirectional microwave sensor	€ 172,00



CODE	MODEL	DESCRIPTION	PRICE
100074/16	ACTIR	Active infrared sensor	€ 195,00



CODE	MODEL	DESCRIPTION	PRICE
100074/21	HR50	Omnidirectional microwave sensor	€ 195,00



CODE	MODEL	DESCRIPTION	PRICE
100074/22	HR100	Infrared sensor for activation and detection safety - Compliant with the EN16005 standard	€ 470,00



CODE	MODEL	DESCRIPTION	PRICE
IXIO-DT3	IXIO	Microwave sensor for activation and active infrared for safety - Compliant with standard EN16005 - DN18650	€ 562,00



CODE	MODEL	DESCRIPTION	PRICE
KEY-98	KEY-09	Wireless touch keyboard - Backlit - IP64 - 2 channels with receiver	€ 251,00

Automations for Sliding Doors and Turnstiles | Accessories



CODE	MODEL	DESCRIPTION	PRICE
RS020	MONI-R	Hi-Security thermal monitor	€ 3.435,00



CODE	MODEL	DESCRIPTION	PRICE
100074/11	GUI	Floor guide for glass door	€ 19,00



CODE	MODEL	DESCRIPTION	PRICE
FOTO9S1A	FOTO9S1A	Amplifier for 1 pair of photocells	€ 70,00



CODE	MODEL	DESCRIPTION	PRICE
0049	GUI-1	Floor guide	€ 21,00



CODE	MODEL	DESCRIPTION	PRICE
FOTO9S2A	FOTO9S2A	Amplifier for 2 pairs of photocells	€ 102,00



CODE	MODEL	DESCRIPTION	PRICE
614	ELT B	Speed complete electric lock	€ 193,00
614/1	ELT G	Gemini complete electric lock	€ 193,00



CODE	MODEL	DESCRIPTION	PRICE
CR10MS	CR10MS	Pair of photocells to be combined with the amplifier	€ 56,00



CODE	MODEL	DESCRIPTION	PRICE
611	AB1	1 door partial abatement system	€ 397,00
612	AB2	2 doors partial abatement system	€ 759,00
613	ANT-S	Battery anti-panic system for Speed	€ 74,00
613/1	ANT-G	Battery anti-panic system for Gemini	€ 74,00



CODE	MODEL	DESCRIPTION	PRICE
608	SEP	Crystal door support profile (price per meter)	€ 140,00



CODE	MODEL	DESCRIPTION	PRICE
122002	CHN	Spare strap at mt for Speed and Gemini	€ 17,00 per mt

DOOR FRAMES PROFILES



CODE	MODEL	DESCRIPTION	PRICE
PF007	PROF-A	Horizontal door frame profile - 1 mt	€ 42,00
PF006	PROF-B	Vertical door frame profile - 1 mt	€ 21,00
0049	GUI-1	Floor guide	€ 42,00
0051	SPAZZ	Brush - 1 mt	€ 35,00

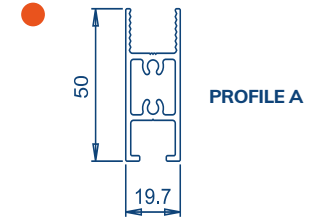
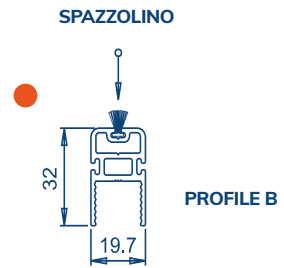
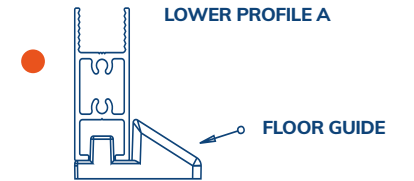
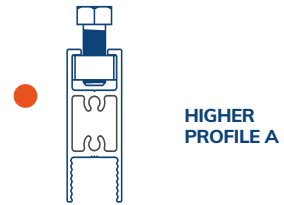
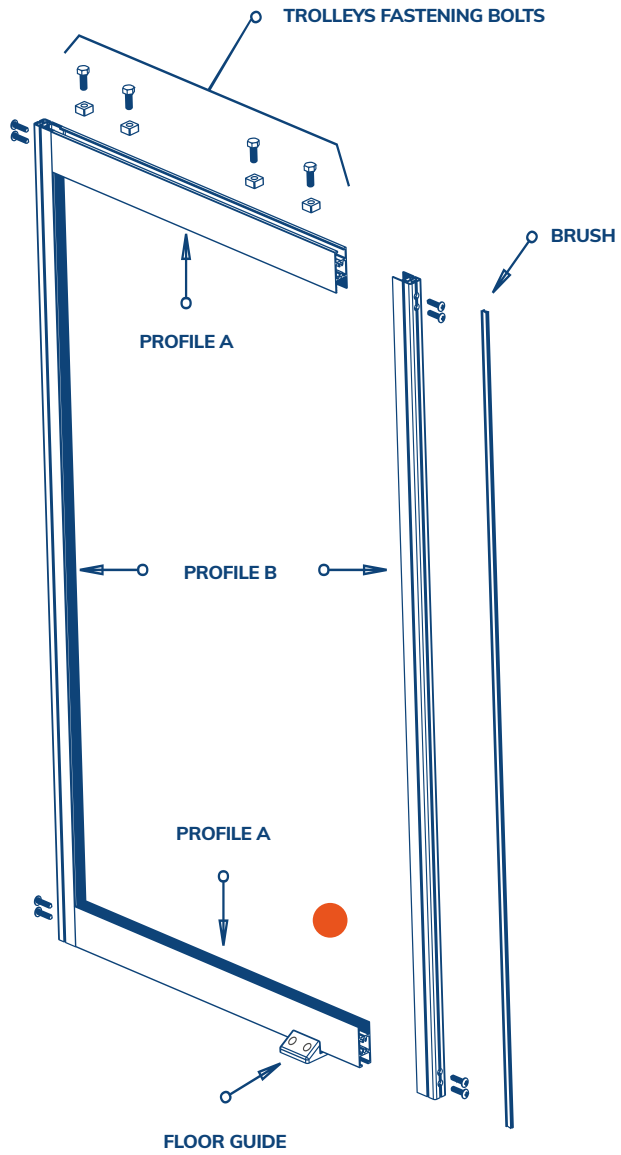

COMPLETE DOORS

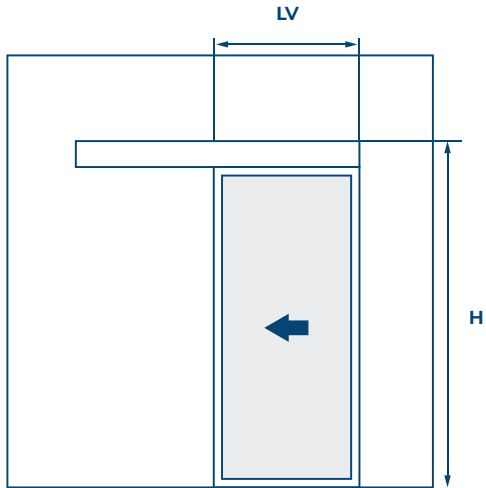

ENTRANCE WITH 1 SLIDING DOOR (RIGHT OR LEFT OPENING)

DESCRIPTION	LVM mm	HVM 3450 mm	HVM 4000 mm
Complete entrance door frame made with automation profiles supplied pre-assembled and with gaskets for glass	1000	Price upon request	Price upon request
	1200	Price upon request	Price upon request
	1600	Price upon request	Price upon request
	2000	Price upon request	Price upon request

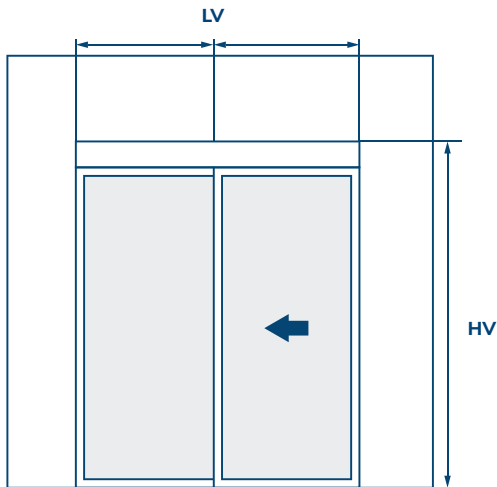

ENTRANCE WITH 1 SLIDING DOOR + 1 FIXED SIDE DOOR (RIGHT OR LEFT OPENING)

DESCRIPTION	LVM mm	HVM 3450 mm	HVM 4000 mm
Complete entrance door frame made with automation profiles supplied pre-assembled and with gaskets for glass	1200	Price upon request	Price upon request
	1600	Price upon request	Price upon request
	2000	Price upon request	Price upon request
	3000	Price upon request	Price upon request

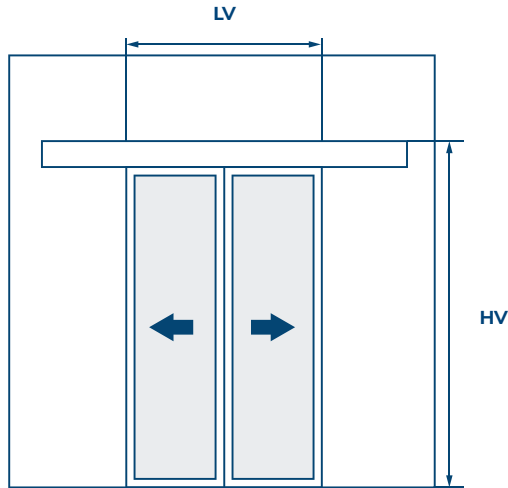

ENTRANCE WITH 2 SLIDING DOORS

DESCRIPTION	LVM mm	HVM 3450 mm	HVM 4000 mm
Complete entrance door frame made with automation profiles supplied pre-assembled and with gaskets for glass	1200	Price upon request	Price upon request
	1600	Price upon request	Price upon request
	2000	Price upon request	Price upon request
	2600	Price upon request	Price upon request
	3000	Price upon request	Price upon request

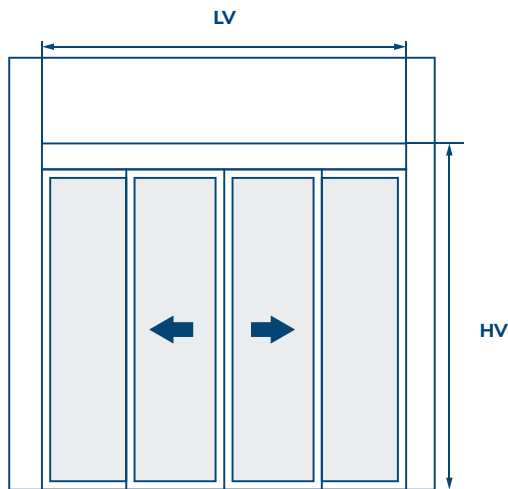

ENTRANCE WITH 2 SLIDING DOORS + 2 FIXED SIDE DOORS

DESCRIPTION	LVM mm	HVM 3450 mm	HVM 4000 mm
Complete entrance door frame made with automation profiles supplied pre-assembled and with gaskets for glass	2000	Price upon request	Price upon request
	3000	Price upon request	Price upon request
	4000	Price upon request	Price upon request
	5000	Price upon request	Price upon request

The background consists of a solid blue field with a large orange triangle on the left side, pointing towards the top right corner.

ELECTRONIC **CONTROL BOARD**

CONTROL BOARD



CODE	MODEL	PRICE
E105	EURO 230 M2	€ 255,00

- Control board 230VAC
- In box
- For Swing Gates 1 or 2 leaf
- Self-learning radio receiver
- Rolling-code and fix code to be selected by switch
- Electric limit switch
- Slowing down function / pedestrian input



CODE	MODEL	PRICE
F101	ELB 230 M2	€ 247,00

- Control board 230VAC
- In box
- For Swing Gates 1 or 2 leaf
- Self-learning radio receiver
- Rolling-code and fix code
- Electric limit switch
- Slowing down function / pedestrian input



CODE	MODEL	PRICE
E112	EURO 230 M2 MINI	€ 240,00

- Control board 230VAC
- In box
- For Swing Gates 1 or 2 leaf
- Self-learning radio receiver
- Rolling-code
- Slowing down function / pedestrian input



CODE	MODEL	PRICE
E102	EURO 230 M1	€ 224,00

- Control board 230VAC
- Sliding Gates, Barriers, Counterweight doors
- Self-learning radio receiver
- Rolling-code and fix code to be selected by switch
- Electric limit switch
- Slowing down function / pedestrian input



CODE	MODEL	PRICE
F103	ELB 24 M2	€ 321,00

- Control board 24VAC
- In box
- For Swing Gates 1 or 2 leaf
- Self-learning radio receiver
- Rolling-code and fix code to be selected by switch
- Electric limit switch
- Slowing down function / pedestrian input



CODE	MODEL	PRICE
E103	EURO 24 M1	€ 220,00

- Control board 24VCC
- Sliding Gates, Barriers, Counterweight doors
- Self-learning radio receiver
- Rolling-code and fix code to be selected by switch
- Electric limit switch
- Slowing down function / pedestrian input

Electronic Control Board | **Control Board**



CODE	MODEL	PRICE
E107	EURO 380 M1	€ 567,00

- Control board 230/380VAC
- In box
- Sliding Gates
- Rolling-code and fix code to be selected by switch



CODE	MODEL	PRICE
S-0215-01	MINI	€ 113,00

- Control board 230VAC
- In box
- Rolling Shutters
- Self-learning radio receiver
- Rolling-code and fix code
- Flashing, courtesy light
- Dead man function
- LED light included in the box

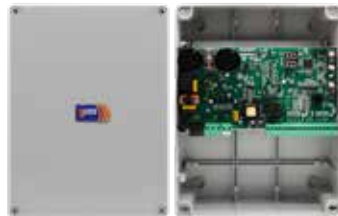

CODE	MODEL	PRICE
Q100	INVERTER	€ 779,00

- Control board 230/380VAC
- In box
- Sliding Gates
- Trimmer speed and strenght setting
- Amperometric sensitivity management
- Dead man function



CODE	MODEL	PRICE
G030	AT7070	€ 167,00

- Control board 24VCC
- Selectional and Counterweight doors
- Self-learning radio receiver
- Rolling-code
- LED for courtesy light



CODE	MODEL	PRICE
CSER1R	ROLLY	€ 113,00

- Control board 230VAC
- In box
- Rolling Shutters
- Self-learning radio receiver
- Rolling-code and fix code
- Flashing, courtesy light
- Dead man function



COD	PRICE
SUNPOWER	€ 618,00

- Power kit with 2 solar panels applicable to all 24VDC automations

Electronic Control Board | **Control Board**



CODE	DESCRIPTION	PRICE
93370000	Control board for controlling 2 dead-man motors - Without radio receiver	€ 70,00



CODE	DESCRIPTION	PRICE
480	Transformer 100 VA - 230 / 24VAC - Toroidal - For Bev2 / Berta / Carrera	€ 70,00
TR006	Transformer 150 VA - 230/20 VAC - Toroidal - For Gemini	€ 70,00



CODE	DESCRIPTION	PRICE
93330000	Control board for controlling 4 dead-man motors - Without radio receiver	€ 212,00



CODE	DESCRIPTION	PRICE
478/1	Transformer 100 VA - 230/24VAC - Lamellar for Utile 70 / Simply	€ 52,00
478/P	Transformer 140 VA - 230/24VAC - Lamellar for Utile 100 / Riki20	€ 75,00
TR003	Transformer 150 VA - 230/20 VAC - Lamellar for Speed Plus - F103	€ 104,00



CODE	DESCRIPTION	PRICE
ALA1	3VA terminal block power supply with 230VAC input and 24VAC output - For photocells and flashing lights	€ 93,00

RADIO SYSTEMS



CODE	MODEL	DESCRIPTION	PRICE
TX01	MULTI2	2 channels remote control - 433,92 mHz - Copyable - Rolling code - Fixing code	€ 31,00



CODE	MODEL	DESCRIPTION	PRICE
E010	ECO-R	5 channels remote control - 433,92 mHz - Rolling code	€ 33,00



CODE	MODEL	DESCRIPTION	PRICE
TX02	MULTI4	4 channels remote control - 433,92 mHz - Copyable - Rolling code - Fixing code	€ 33,00



CODE	MODEL	DESCRIPTION	PRICE
164/1	FRQ	Frequency counter	€ 353,00



CODE	MODEL	DESCRIPTION	PRICE
TX-E	ECO-E	4 channels remote control - 433,92 mHz - Rolling code	€ 30,00



CODE	MODEL	DESCRIPTION	PRICE
1000/1	EHT	Plug-in hybrid 433 mHz - Super heterodyne - Universal	€ 39,00
1000	SCH	Plug-in hybrid 433 mHz - Shielded - Universal	€ 39,00



CODE	MODEL	DESCRIPTION	PRICE
E142	SRM	External radio receiver in box 433 mHz - 1 channel - 12/24VCC - Small size - With aerial	€ 97,00



CODE	MODEL	DESCRIPTION	PRICE
E002	SMR24C2	External radio receiver in box 433mHz - 2 channels - 12/24VCC - Rolling code with aerial	€ 112,00
E003	SMR220C2	External radio receiver in box 433 mHz - 2 channels - 230VAC - Rolling code with aerial	€ 119,00



CODE	MODEL	DESCRIPTION	PRICE
210/1	ANT	Aerial with 4,50 mt cable and bracket - 433 mHz	€ 34,00

RADIO - RANGE 1 KM - BIDIRECTIONAL



CODE	MODEL	DESCRIPTION	PRICE
E001	SMR220C4	External radio receiver in box 433 mHz - 4 channels - 230VCC - Rolling code with aerial	€ 253,00



CODE	MODEL	DESCRIPTION	PRICE
519/0020	MARCONI	4-channel receiver with aerial	€ 722,00



CODE	MODEL	DESCRIPTION	PRICE
E062	SRT-MINI	Plug-in receiver 433 mHz - 1 channel - Rolling code	€ 92,00



CODE	MODEL	DESCRIPTION	PRICE
519/0022	MARCONI	4-channel remote control	€ 192,00

The background consists of a solid orange triangle on the left side, pointing towards the top right, and a solid blue area on the right side.

AUTOMATION **ACCESSORIES**

ACCESS CONTROL



CODE	DESCRIPTION	PRICE
ANT1	Hands free system for vehicles and people entry or exit 1 entrance	€ 1.039,00
ANT2	Hands free system for vehicles and people entry and exit 2 entrances	€ 1.890,00
1000925	Active tag	€ 193,00



CODE	DESCRIPTION	PRICE
MTPADPBK-EH-SA	Stand alone keypad with proximity reader - 1 relay - 12/24V - IP65	€ 321,00



CODE	DESCRIPTION	PRICE
B100SA	Stand alone biometric reader for outdoor use 97 fingerprints IP65 - Silver	562,00



CODE	DESCRIPTION	PRICE
INOX-SA	Metallic keyboard Slim line gray / chrome stand alone - 1 relay - 12/24V - IP65	€ 372,00



CODE	DESCRIPTION	PRICE
B100BK-SA-KIT	Stand alone biometric reader kit for external 97 fingerprints IP65 + RTT - Black edition	€ 767,00



CODE	DESCRIPTION	PRICE
VKP99	Stand alone vandal-proof metal keypad - 2 relays - 99 codes - 12/24V - IP65	€ 389,00



CODE	DESCRIPTION	PRICE
MTPADS-SA	Stand alone metal keypad 1000 codes - 1 relay 12/24V - IP65 - Silver	€ 333,00



CODE	DESCRIPTION	PRICE
MINI-SA2	Stand alone proximity reader - 1 relay - 12/24V - IP65	€ 321,00

Automation Accessories | **Access Control**



CODE	MODEL	DESCRIPTION	PRICE
EASY NEW	KEYPAD	Vandal-proof cable keypad - IP67 protection degree - 30 codes - 12V AC DC power supply	€ 281,00

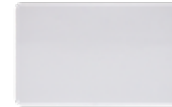

CODE	DESCRIPTION	PRICE
CA001	125 khz card	€ 18,00



CODE	MODEL	DESCRIPTION	PRICE
KEY-98	KEY-9	Wireless touch keypad - Backlit - IP64 - 2 channels with receiver	€ 251,00



CODE	DESCRIPTION	PRICE
BA001	125 khz keychain	€ 18,00



CODE	MODEL	DESCRIPTION	PRICE
SPROX	TAG 1	Autonomous proximity reader	€ 201,00
SKEY	TAG 2	Key for TAG reader 1	€ 15,00
E001	SMR23C4	External receiver for TAG	€ 253,00



CODE	DESCRIPTION	PRICE
FA001	125 khz bracelet	€ 18,00



CODE	MODEL	DESCRIPTION	PRICE
1434/2	GSM-C	Gate opening GSM module - 2 channels - With aerial	€ 333,00



CODE	DESCRIPTION	PRICE
XPR-FLEX30	Flexible steel cable glands - L 300x12 mm - Stainless steel	€ 97,00
XPR-FLEX50	Flexible steel cable glands - L 500x12 mm - Stainless steel	€ 106,00



CODE	DESCRIPTION	PRICE
MC-MINI	Single stainless steel cover for readers	€ 172,00

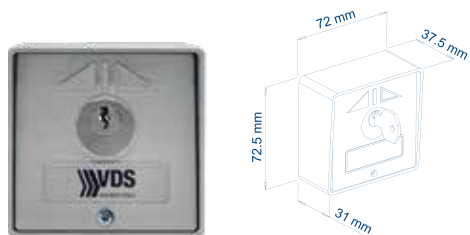

CODE	MODEL	DESCRIPTION	PRICE
198/2	PLA	Outdoor selector - Start / stop - Aluminum	€ 45,00
178/CA	PLA2	Pair of selectors with same coding	€ 90,00

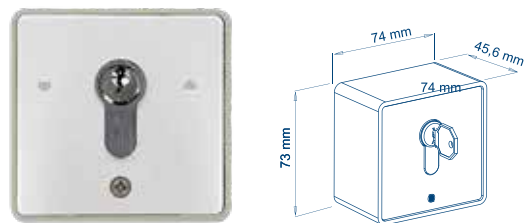

CODE	MODEL	DESCRIPTION	PRICE
198/ECO	PLA-E	Outdoor selector - Start / Stop - Aluminum - European cylinder	€ 70,00

SELECTOR TECHNICAL FEATURES

Protection degree	IP54
Operating temperature	-20 / +85° C
Switch absorption	16 A

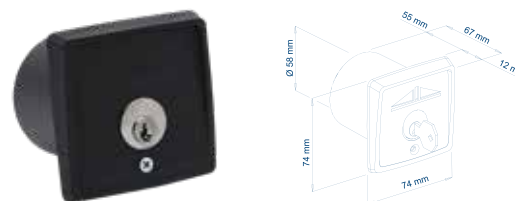

CODE	MODEL	DESCRIPTION	PRICE
200	INK	Wall selector - ABS plastic	€ 29,00
STP013	INK-R	Round adapter, for old series	€ 4,00
200/C	INK-C	Pair of selectors with same coding	€ 58,00

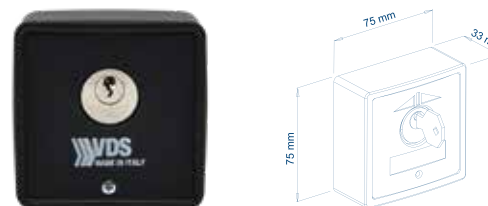

CODE	MODEL	DESCRIPTION	PRICE
198/5	PLA-ABS	Outdoor selector - Start / stop - Technopolymer	€ 26,00
198/CP	PLA-ABS2	Pair of selectors with same coding	€ 51,00

Automation Accessories | Access Control

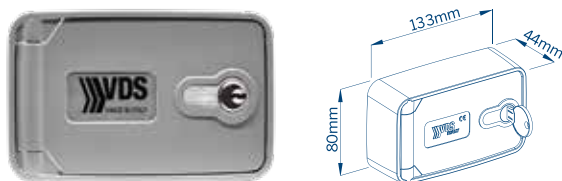

CODE	MODEL	DESCRIPTION	PRICE
854	MAYA	Blindino wall selector with electro-brake - Push-button - Aluminum - European cylinder	€ 85,00
854/1	MAYA1	Blindino wall selector with electro-brake - Aluminum - European	€ 67,00
854/CP	MAYA1C	cylinder Pair of selectors with the same coding - With button	€ 170,00
854/C	MAYA-C	Pair of selectors with release and same coding	€ 135,00

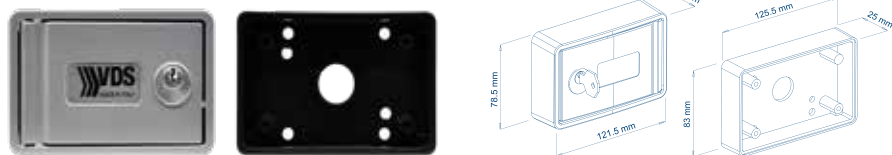

CODE	MODEL	DESCRIPTION	PRICE
754/1	BLINDOR	Blindino wall selector with electro-brake - Push-button - Aluminum	€ 85,00
754/6	BLINDOR1	Blindino wall selector with electro-brake - Aluminum	€ 67,00
754/CS	BLINDOR-CS	Pair of selectors with release and same coding	€ 135,00
754/CP	BLINDOR-CP	Pair of selectors with same coding - With button	€ 168,00
754/2	BLB	Wall fixing base	€ 9,00



CODE	MODEL	DESCRIPTION	PRICE
QDM1	230V	Loop detector - 230V - 1 channel - With box	€ 269,00
SMR-24	24V	Loop detector - 12/24V - 1 channel - With box	€ 256,00



CODE	MODEL	DESCRIPTION	PRICE
262598	PROLOOP	Loop detector - 230V - 1 channel - Din bar	€ 401,00
550/1224	MAGNETIX	Loop detector - 12/24V - 1 channel - Din bar	€ 299,00



CODE	MODEL	DESCRIPTION	PRICE
263	WIRE 1	Pre-assembled loop to be buried 3x2 mt + 6 mt cable	€ 80,00
264	WIRE 2	Pre-assembled loop to be buried e 5x2 mt + 10 mt cable	€ 87,00

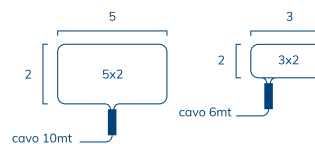

SAFETY AND DETECTION



CODE	MODEL	DESCRIPTION	PRICE
12/T	FS	Pair of wall photocells - Slim - Range 40 mt - Power supply 12/24V	€ 75,00



CODE	MODEL	DESCRIPTION	PRICE
FT25B	FT BAT	Pair of photocells with batteries - Range 10 mt - 12/24V	€ 111,00
BATF	BATTERY	Spare battery kit	€ 37,00



CODE	MODEL	DESCRIPTION	PRICE
12/C	TECH2	Pair of wall photocells - Range 15 mt - NO NC contact - Power supply 12/24V	€ 64,00



CODE	MODEL	DESCRIPTION	PRICE
RP25	FTCS	Mirror photocell - Range 12 mt - Power supply 12/24V	€ 147,00
589/8150	FTCS	Square catadioptric 100x100 mm - Range 15 mt	€ 52,00
589/8122		Black case for protection against rain, bumps and reflections for photocell	€ 17,00
589/0200		Black case to protect rain, shocks and reflections for round reflector	€ 17,00
589/8121		Anti-condensation accessory for reflector diameter 82 mm	€ 9,00



CODE	MODEL	DESCRIPTION	PRICE
12/FVG180	FVG180	Pair of 180 ° adjustable wall photocells - Range 12 mt - Power supply 12/24V	€ 71,00



CODE	MODEL	DESCRIPTION	PRICE
12/FOTO-LAMP	FL	Pair of wal adjustable photocells with flashing light - Range 12 mt - Power supply 12/24V	€ 80,00



CODE	MODEL	DESCRIPTION	PRICE
18	FTINC	Pair of embedded photocells - Range 12 mt - Power supply 12/24V	€ 72,00
250	CN-IN	Metal container for wall application	€ 28,00



CODE	MODEL	DESCRIPTION	PRICE
12/FB	FB	Pair of armored wall photocells - 180° adjustable - Range 15 mt - Power supply 12/24V	€ 150,00

Automation Accessories | **Safety and Detection**



CODE	MODEL	DESCRIPTION	PRICE
790/0028	FALCON	Microwave detector for industrial doors	€ 664,00



CODE	DESCRIPTION	PRICE
E050	Wireless safety band - Transmitter	€ 189,00



CODE	MODEL	DESCRIPTION	PRICE
551/0620	RM620	Simplified microwave detector for industrial doors	€ 699,00



CODE	DESCRIPTION	PRICE
E051	Wireless safety band - Receiver	€ 189,00



CODE	MODEL	DESCRIPTION	PRICE
790/2010	FLATSCAN SW	Laser sensor for swing doors - Single LEFT	€ 2.211,00
790/2011	FLATSCAN SW	Laser sensor for swing doors - Single RIGHT	€ 2.211,00
790/2022	FLATSCAN DX-SX	Double laser sensor for swing doors - RIGHT LEFT	€ 4.077,00



CODE	DESCRIPTION	PRICE
TXR-P8	Wireless safety band - Transmitter with 2 batteries supplied	€ 175,00



CODE	MODEL	DESCRIPTION	PRICE
HYU-444	444	ANPR camera for license plate reading applicable on all VDS automations	€ 2.370,00



CODE	DESCRIPTION	PRICE
RXR-P8	Radio safety band - Receiver	€ 175,00



CODE	MODEL	DESCRIPTION	PRICE
230/5	BS01	1,5 mt sensitive edge - H 70 mm - Black	€ 105,00
230/3	BS01	1,7 mt sensitive edge - H 70 mm - Black	€ 110,00
230/1	BS01	2 mt sensitive edge - H 70 mm - Black	€ 117,00
230/4	BS01	2,5 mt sensitive edge - H 70 mm - Black	€ 127,00
230/7	BS01	3 mt sensitive edge - H 70 mm - Black	€ 138,00
230/8	BS01	4 mt sensitive edge - H 70 mm - Black	€ 150,00



CODE	DESCRIPTION	PRICE
BS01-C15NG	1,5 mt sensitive edge - H 70 mm - Black/Yellow	€ 118,00
BS01-C17NG	1,7 mt sensitive edge - H 70 mm - Black/Yellow	€ 123,00
BS01-C20NG	2 mt sensitive edge - H 70 mm - Black/Yellow	€ 128,00
BS01-C25NG	2,5 mt sensitive edge - H 70 mm - Black/Yellow	€ 142,00
BS01-C30NG	3 mt sensitive edge - H 70 mm - Black/Yellow	€ 154,00
BS01-C40NG	4 mt sensitive edge - H 70 mm - Black/Yellow	€ 163,00



CODE	DESCRIPTION	PRICE
BPM0-S50NE	Hand protection edge - 5 mt kit	€ 241,00



CODE	MODEL	DESCRIPTION	PRICE
CP20-S30	CP20	3 mt low profile passive edge - H 30 mm	€ 85,00
CP20-S40	CP20	4 mt low profile passive edge - H 30 mm	€ 108,00
CP20-S50	CP20	5 mt low profile passive edge - H 30 mm	€ 138,00



CODE	DESCRIPTION	PRICE
BS10-C15NE	Edge with end in soft and shock-sensitive material - 1,5 mt - H 75 mm - Black	€ 126,00
BS10-C17NE	Edge with end in soft and shock-sensitive material - 1,7 mt - H 75 mm - Black	€ 134,00
BS10-C20NE	Edge with end in soft and shock-sensitive material - 2 mt - H 75 mm - Black	€ 139,00
BS10-C25NE	Edge with end in soft and shock-sensitive material - 2,5 mt - H 75 mm - Black	€ 151,00
BS10-C30NE	Edge with end in soft and shock-sensitive material - 3 mt - H 75 mm - Black	€ 161,00
BS10-C40NE	Edge with end in soft and shock-sensitive material - 4 mt - H 75 mm - Black	€ 182,00



CODE	DESCRIPTION	PRICE
BP10-C15NE	1,5 mt passive edge - H 75 mm - Black	€ 105,00
BP10-C20NE	2 mt passive edge - H 75 mm - Black	€ 117,00
BP10-C30NE	3 mt passive edge - H 75 mm - Black	€ 138,00
BP10-C15NG	1,5 mt passive edge - H 75 mm - Black/Yellow	€ 118,00
BP10-C20NG	2 mt passive edge - H 75 mm - Black/Yellow	€ 1.198,00
BP10-C30NG	3 mt passive edge - H 75 mm - Black/Yellow	€ 154,00



CODE	MODEL	DESCRIPTION	PRICE
232	CP30	2 mt low profile sensitive edge - H 30 mm	€ 118,00
233	CP30	2,5 mt low profile sensitive edge - H 30 mm	€ 126,00
234	CP30	3 mt low profile sensitive edge - H 30 mm	€ 133,00
235	CP30	3,5 mt low profile sensitive edge - H 30 mm	€ 138,00
236	CP30	4 mt low profile sensitive edge - H 30 mm	€ 189,00
237	CP30	5 mt low profile sensitive edge - H 30 mm	€ 207,00
CP30-KL3	KL3	3-sided kit for divisions	€ 15,00

Automation Accessories | **Safety and Detection**



CODE	DESCRIPTION	PRICE
NASTRO-R	Reflective adhesive tape - Red - 1 mt	€ 11,00



CODE	DESCRIPTION	PRICE
NASTRO-RB	Reflective adhesive tape - Red and White - 1 mt	€ 11,00



CODE	DESCRIPTION	PRICE
NASTRO-G	Reflective adhesive tape - Yellow - 1 mt	€ 11,00



CODE	DESCRIPTION	PRICE
ACA085801ZB	Anti-fall galvanized ring	€ 58,00



CODE	DESCRIPTION	PRICE
NASTRO-B	Reflective adhesive tape - White - 1 mt	€ 11,00



CODE	MODEL	DESCRIPTION	PRICE
AC02-200	700	Stainless steel fall arrest cable - 700 mm	€ 35,00



CODE	DESCRIPTION	PRICE
NASTRO-GN	Reflective adhesive tape - Black and Yellow - 1 mt	€ 11,00



CODE	MODEL	DESCRIPTION	PRICE
AC02-100	515	Stainless steel fall arrest cable - 515 mm	€ 29,00

SIGNALING

CODE	MODEL	DESCRIPTION	PRICE
23/8	WAVE LED	LED Flashing light 12/24/230V - Different type of flashing	€ 75,00
23/4	BASE WAVE	Wall fixing base	€ 9,00

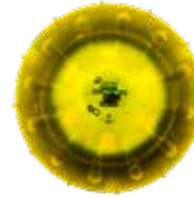

CODE	MODEL	DESCRIPTION	PRICE
CS3137/B	LAR-3	12/24V wall flashing light	€ 59,00



CODE	MODEL	DESCRIPTION	PRICE
Z23	WHITE	Steady flashing light 230VAC - Fixing base	€ 43,00
Z25	BLACK	Steady flashing light 230VAC - Fixing base	€ 43,00



CODE	MODEL	DESCRIPTION	PRICE
550/1036	ALF-G	12/24V/230V wall flashing light	€ 92,00

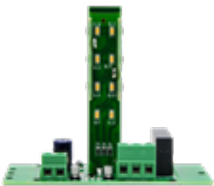

CODE	DESCRIPTION	PRICE
ER-LED	24/230V LED module	€ 52,00
ER-LED/S	24/230V LED module with buzzer	€ 70,00



CODE	MODEL	DESCRIPTION	PRICE
550/1040	MICRO-T	12/24V wall flashing light - Yellow	€ 64,00



CODE	DESCRIPTION	PRICE
K-M-LED12/24V	24/230V LED module with aerial	€ 41,00
K-M-LED230V	230V LED module with aerial	€ 52,00



CODE	MODEL	DESCRIPTION	PRICE
550/1041	MICRO-T	12/24V signaling module - Red	€ 70,00



CODE	MODEL	DESCRIPTION	PRICE
550/1045	MICRO-T	Wall micro-traffic light, 2 lights - Red-green - 12/24V	€ 67,00



CODE	MODEL	DESCRIPTION	PRICE
550/3018	SEM-2	Traffic light, 2 lights - Red-Green - 12/24V	€ 326,00



CODE	MODEL	DESCRIPTION	PRICE
550/3040	SEM-1	Traffic light 1 light - Red - 12/24V	€ 223,00



CODE	MODEL	DESCRIPTION	PRICE
550/3025	SEM-3	Traffic light, 3 lights - Red, Yellow, Green - 12/24V	€ 538,00



CODE	MODEL	DESCRIPTION	PRICE
550/3050	SEM-1	Traffic light 1 light - Green - 12/24V	€ 223,00



CODE	MODEL	DESCRIPTION	PRICE
511/2050	QUAD	230V traffic light control board	€ 396,00



CODE	MODEL	DESCRIPTION	PRICE
550/3012	CONV	230/12V converter	€ 64,00

MECHANICAL



CODE	MODEL	DESCRIPTION	PRICE
167/V	VDS-VL	Vertical electric lock 12V - 3 keys supplied	€ 241,00



CODE	MODEL	DESCRIPTION	PRICE
ELT6-220	ELT220	Drop electric lock 230V	€ 161,00
ELT6-24	ELT24	Drop electric lock 24V	€ 161,00
ELT6-12	ELT12	Drop electric lock 12V	€ 161,00



CODE	MODEL	DESCRIPTION	PRICE
167/E	ELC	Complete central left/right electric lock 12V - With button - 3 keys supplied	€ 124,00



CODE	MODEL	DESCRIPTION	PRICE
167	ELT	Complete central left/right electric lock - With button 12V - 3 keys supplied	€ 138,00
168/1	ELT-BASE	Iron fixing base	€ 34,00



CODE	MODEL	DESCRIPTION	PRICE
167/1	A721	Complete central left/right electric lock 12V - Without	€ 207,00
167/2	A731	Complete central left/right electric lock 12V - With button	€ 218,00
107022100	BSTP	Booster Plus	€ 389,00
107022000	BST	Booster	€ 161,00
107023000	MICRO	Microswitch	€ 87,00
107025100	BOB	Coil 12V	€ 87,00

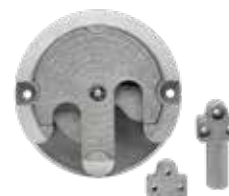

CODE	MODEL	DESCRIPTION	PRICE
755	BL2	Blocco anta orizzontale	€ 91,00

In die-cast aluminum to be used in combination with an electric lock with operator without mechanical lock with aluminum pin



CODE	MODEL	DESCRIPTION	PRICE
265	BL1	Vertical leaf block	€ 54,00

In galvanized steel and B14 bronze to be used in combination with an electric lock with actuator without mechanical lock

Automation Accessories | **Mechanical**



CODE	MODEL	DESCRIPTION	PRICE
RVS	RVS	Slowdown system for sloping gates	779,00



CODE	MODEL	DESCRIPTION	PRICE
216/1	CRM2	Nylon rack with metal insert - Complete with accessories - 1 mt - Black	€ 20,00
216/G	CRM2	Nylon rack with metal insert - Complete with accessories - 1 mt - Grey	€ 31,00
216/GL	CRM2	Nylon rack with metal insert - Complete with accessories - 1 mt - Yellow	€ 32,00
216/B	CRM2	Nylon rack with metal insert - Complete with accessories - 1 mt - White	€ 32,00



CODE	MODEL	DESCRIPTION	PRICE
217	CRZ	Galvanized rack M4 - 30x12 complete with spacers - 1 mt	€ 28,00



CODE	MODEL	DESCRIPTION	PRICE
218	CRZ 8	Galvanized rack M4 - 30x8 complete with spacers - 1 mt	€ 26,00

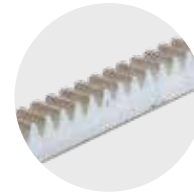

CODE	MODEL	DESCRIPTION	PRICE
218/1	CRZ B	Galvanized rack M4 - 22x22 - 1 mt	€ 41,00
218/2	CRZ B2	Galvanized rack M4 - 22x22 - 2 mt	€ 74,00

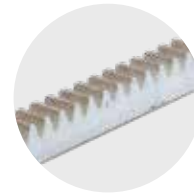

CODE	MODEL	DESCRIPTION	PRICE
303001	CRZ S	Galvanized rack M6 - 30x30 - 1 mt	€ 103,00
303001/1	CRZ S2	Galvanized rack M6 - 30x30 - 2 mt	€ 171,00



CODE	MODEL	DESCRIPTION	PRICE
DAP	DAP	Adjustable screw-on spacer - Pack of 3 pcs	€ 14,00
STAFFAPIU	EASY	Adjustable screw-on spacer - Pack of 3 pcs	€ 21,00



CODE	MODEL	DESCRIPTION	PRICE
121032	NT1	Pawl to be welded	€ 4,00
113022	NT2	Latch to be screwed on	€ 6,00

GENERIC



CODE	MODEL	DESCRIPTION	PRICE
273	CLA 15	Aluminum column for Tech2 photocells - H 15 cm	€ 35,00



CODE	MODEL	DESCRIPTION	PRICE
244	CLA 50	Column in anodized aluminum - H 50 mm	€ 52,00
248	CLA 100	Column in anodized aluminum - H 100 mm	€ 104,00
244/E	CLA G	Grey column - H 50 cm	€ 80,00
244/B	CLA N	Black column - H 50 cm	€ 80,00
244/C	CLA B	White column - H 50 cm	€ 80,00
124569	CLA C	Fixing plate for column - H 50 cm	€ 26,00



CODE	MODEL	DESCRIPTION	PRICE
272	CSELL	Aluminum column with selector - H 100 cm	€ 126,00
272/1	CSELL F	Aluminum column with selector - H 100 cm - Predisposition for photocells	€ 150,00
248/2	100-2	Aluminum column - H 100 cm - Predisposition for double photocell	€ 161,00
124569	CLA C	Fixing plate for column	€ 26,00



CODE	MODEL	DESCRIPTION	PRICE
COLO50	CLN	Universal column in aluminum - H 50 cm	€ 75,00
COLO100	CLN	Universal column in aluminum - H 100 cm	€ 138,00
COLO125	CLN	Universal column in aluminum - H 125 cm	€ 150,00
ADT-INC	CLN-INC	Built-in adapter	€ 24,00
CLN8-PB	B-CLN	Column base	€ 24,00
CLN8-PST	B-CNT	Fixing plate	€ 41,00



CODE	MODEL	DESCRIPTION	PRICE
PFC1	FC	Setback with pole	€ 35,00



CODE	MODEL	DESCRIPTION	PRICE
PFC2	FCP	Wall stop	€ 30,00

Automation Accessories | **Generic**



CODE	DESCRIPTION	PRICE
420/2	12V battery - 1,2 AH	€ 37,00

For Simply / Carrera / Speed



CODE	DESCRIPTION	PRICE
23	Battery for remote control E010 - 12V - 23A	€ 5,00
25	Battery for remote control - 12V - 27A	€ 6,00



CODE	DESCRIPTION	PRICE
420	12V battery - 7 AH	€ 50,00

For Bev2 / Berta



CODE	DESCRIPTION	PRICE
24	Lithium battery - CR 2032 3V - For remote control Tx01/Tx02	€ 5,00
26	Lithium battery - CR 2016	€ 5,00
27	Lithium battery - CR 1620	€ 6,00



CODE	DESCRIPTION	PRICE
420/1	12V battery - 2 AH	€ 43,00



CODE	DESCRIPTION	PRICE
OKITMI5-PR	Blueforce Smart Kit - Impact force measurement instrument	€ 5.152,00



CODE	DESCRIPTION	PRICE
RN0250	Cable for gates - 2X0,50 - 100 mt skein	€ 109,00
RN0450	Cable for gates - 4X0,50 - 100 mt skein	€ 143,00
RN0550	Cable for gates - 5X0,50 - 100 mt skein	€ 195,00
RN0210	Cable for gates - 2X1,00 - 100 mt skein	€ 167,00
RN0410	Cable for gates - 4X1,00 - 100 mt skein	€ 285,00
RN0315	Cable for gates - 3X1,50 - 100 mt skein	€ 321,00
RN0415	Cable for gates - 4X1,50 - 100 mt skein	€ 435,00



CODE	DESCRIPTION	PRICE
PG1M9W01	Emergency button - Ø 90 mm - Red - NC contact - Wall mounting	€ 59,00



CODE	DESCRIPTION	PRICE
165B	Warning sign	€ 10,00



CODE	DESCRIPTION	PRICE
PG8M9W10	Control button - Ø 90 mm - Black - NA contact - Wall mounting	€ 59,00



CODE	DESCRIPTION	PRICE
19/O	Dielectric hydraulic oil - 1 lt	€ 21,00
19/P	Dielectric hydraulic oil - 2 lt	€ 42,00
19/Q	Dielectric hydraulic oil - 5 lt	€ 104,00



CODE	DESCRIPTION	PRICE
AC01-100	Galvanized cabinet with key for control board	€ 353,00



CODE	DESCRIPTION	PRICE
CC2750154	Spare cable set for overhead doors	€ 70,00



CODE	DESCRIPTION	PRICE
AC01-200VA	Support for control board	€ 207,00



CODE	DESCRIPTION	PRICE
ST-450	Magnetic contact for overhead door	€ 80,00

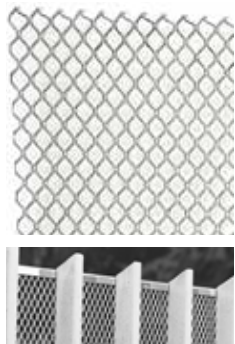

CODE	DESCRIPTION	PRICE
RT-H100	Expanded mesh for motorized openings and gates Compliant with CEI EN 60529 - H 100	€ 80,00 price per mt
RT-H125	Expanded mesh for motorized openings and gates Compliant with CEI EN 60529 - H 125	€ 104,00 price per mt
RT-H150	Expanded mesh for motorized openings and gates Compliant with CEI EN 60529 - H 150	€ 138,00 price per mt
RT-H200	Expanded mesh for motorized openings and gates Compliant with CEI EN 60529 - H 200	€ 167,00 price per mt
PR-RT	Profile for finishing - 3 mt	€ 34,00

TECHNICAL FEATURES

DIGITAL KEYBOARD

Available programs:

- Entry
- Exit
- Normal
- Partial
- Open
- Closed

CART

- Made of sturdy laser-cut steel laminate
- Supporting wheels in technopolymer molded directly on the bearing
- Anti-slip system with adjustable metal elements

POWER SUPPLY

Composition: 120 VA transformer in box and protected by fuse

OPERATOR UNIT

- 24 VDC motor, drive shaft supported by ball bearing
- Double reading optical encoder 100 pulses
- Die-cast aluminum wheel drive
- Locking system made by an industrial solenoid mounted directly on the return wheel operable by a steel cable

CONTROL UNIT

- Microprocessor with built-in battery charger management and removable terminals
- Interlocking management
- Anti-crushing safety
- Slowdown speed adjustment on the board
- Remote programming via digital selector JET01
- Security tests
- Air curtain management

CHART WORKS

- Feature included
- Feature not included

	EURO 230 M2	EURO 230 M2 MINI	ELB 24 M2	EURO 230 M1	EURO 24 M1
MOTOR SUPPLY	230 VAC	230 VAC	24 VCC	230 VAC	24 VCC
MOTORS	2	2	2	1	1
MOTOR ACCESSORIES	●	●	●	●	●
SAFETY SUPPLY	●	●	●	●	●
START INPUT	●	●	●	●	●
PEDESTRIAN INPUT	●	—	●	●	●
STOP INPUT	●	●	●	●	●
LIMIT SWITCH INPUT	●	—	—	●	●
PHOTOCELLS INPUT	●	●	●	●	●
SAFETY EDGE INPUT	●	●	●	●	●
SENSOR RPM INPUT	—	—	—	●	●
PLUG-IN RADIO INPUT	—	—	●	—	—
ON BOARD RADIO RECEIVER	●	●	●	●	●
FLASHING INPUT	●	●	●	●	●
COURTESY LIGHT INPUT	●	—	—	●	●
ELECTRO LOCK INPUT	●	●	●	—	—
STEP BY STEP	●	●	●	●	●
STEP BY STEP WITH STOP	●	●	●	●	●

Chart Works

- Feature included
- Feature not included

	EURO 230 M2	EURO 230 M2 MINI	ELB 24 M2	EURO 230 M1	EURO 24 M1
CONDOMINIUM	●	●	●	●	●
DEAD MAN	—	—	—	—	—
RAM PUSH	●	●	●	—	—
AUTOMATIC CLOSER	●	●	●	●	●
FASTER CLOSER	—	—	—	—	—
PHOTOCELLS IN OPENING	●	●	●	●	●
PHOTOCELLS IN CLOSING	●	●	●	●	●
TORQUE ADJUSTING	●	●	●	●	●
SLOW DOWN	●	●	●	●	●
ANTI-CRUSHING	●	—	●	●	●
EXTENSION WORKING TIME	●	●	●	●	●
BATTERY INPUT	—	—	●	●	●
SOLAR PANEL INPUT	—	—	●	●	●
THREE-PHASE SWITCH	—	—	—	—	—
PHOTOCELL TEST	—	—	—	—	—
FREQUENCY 433 MHZ	●	●	●	●	●
HYDRAULIC BLOCK MAINTENANCE	●	●	—	—	—

CHART WORKS

- Feature included
- Feature not included

	EURO 380 M1	Q 100 INVERTER	ROLLY	MINI	AT 7070
MOTOR SUPPLY	230 / 380 VAC	230 / 380 VAC	230 VAC	230 VAC	24 VCC
MOTORS	1	1	1	1	1
MOTOR ACCESSORIES	●	●	●	●	●
SAFETY SUPPLY	●	●	●	●	●
START INPUT	●	●	●	●	●
PEDESTRIAN INPUT	●	●	—	—	●
STOP INPUT	●	●	—	—	●
LIMIT SWITCH INPUT	●	●	—	—	●
PHOTOCELLS INPUT	●	●	●	●	●
SAFETY EDGE INPUT	●	●	—	—	—
SENSOR RPM INPUT	—	—	—	—	●
PLUG-IN RADIO INPUT	●	—	—	●	—
ON BOARD RADIO RECEIVER	●	—	●	●	●
FLASHING INPUT	●	●	—	●	●
COURTESY LIGHT INPUT	●	—	—	—	●
ELECTRO LOCK INPUT	—	—	—	—	—
STEP BY STEP	●	●	●	●	●
STEP BY STEP WITH STOP	●	●	●	●	●

Chart Works

- Feature included
- Feature not included

	EURO 380 M1	Q 100 INVERTER	ROLLY	MINI	AT 7070
CONDOMINIUM	●	●	—	—	●
DEAD MAN	●	●	●	●	—
RAM PUSH	—	●	—	—	—
AUTOMATIC CLOSER	●	●	●	●	●
FASTER CLOSER	—	—	—	—	—
PHOTOCELLS IN OPENING	●	●	—	—	—
PHOTOCELLS IN CLOSING	●	●	●	●	●
TORQUE ADJUSTING	●	●	—	—	●
SLOW DOWN	●	●	—	—	●
ANTI-CRUSHING	●	●	—	—	●
EXTENSION WORKING TIME	●	●	●	●	●
BATTERY INPUT	—	—	—	—	●
SOLAR PANEL INPUT	—	—	—	—	●
THREE-PHASE SWITCH	●	—	—	—	—
PHOTOCELL TEST	—	—	—	—	—
FREQUENCY 433 MHZ	●	—	●	●	●
HYDRAULIC BLOCK MAINTENANCE	—	—	—	—	—

GENERAL SALES CONDITIONS

PURCHASING ORDERS

Placing a purchase order implies the acceptance of the following General Conditions of Sale:

ARTICLE 1: DELIVERY TERMS, TRANSPORT AND PACKAGING

The goods mentioned in the contract is sold ex-works. Shipment, only if required by the buyer, might be effected by transport agent named by VDS if not differently specified. All freight charges and any risks are to be considered as buyer charge - the goods will be packaged according to VDS experience. VDS is totally exempt from any responsibilities for losses or damages for goods regularly package.

ARTICLE 2: DELIVERY TERMS

VDS agrees with customers each time the standard delivery terms according to purchased goods, if not clearly indicated in the confirmaion of the orders. VDS furthermore accepts any eventual change in the standard delivery time and in case to communicate this change by order confirmation or in written document.

ARTICLE 3: PRICES CHANGES

The change in costs, also occurring during the supply, may determine the change in the agreed prices.

ARTICLE 4: CLAIMS

Claims against the quality of the goods or with reference to supplied goods must be sent to the address of the selling company by registred letter within and not further 8 days from the delivery date. No returns will be accepted unless by written authorization of VDS.

ARTICLE 5: PAYMENT

The payment terms are those mentioned on the order confirmation and on the invoices issued from VDS. All the payments must be effected to the address of VDS. The delay in payment even only for part of the invoice, will cancel the discount if granted and will cancel any agreed delay of credit or delayed payment agreed terms even rate, starting from the expiry date of the agreed terms and in the suspension of further supplies. The charges for any eventual outstanding will be debited to the buyer. VDS is totally authorized to issue drafts against the buyer in order to collect the interest, even if claims or disputes are in process.

ARTICLE 6: GUARANTEE: DURATION, EXTENSION, LIMITS

VDS guarantees his products and accessory components for a period of 2 years from the selling date, during which assistance is considered free. The replaced components will remain the property of VDS. All transport costs necessary for the provision of the guarantee in the forms mentioned above are the responsibility of the buyer. VDS reserves the right to refuse the guarantee if:

- The electric accessories and automation components have been used without observing the standard connection diagrams which have been designed for.
- The gearmotors have been used for uses other than those established.
- The assembly and electrical connection instructions have been applied inconsistently with the screens contained in the packaging of the goods.
- Maintained contact pushbutton panels or key selectors have been used for several gearmotors or with a single command.
- No connections have been made according to UNI / CE regulations
- The gearmotors have been disassembled or manipulated without the written authorization of VDS.

After the warranty terms have elapsed, assistance will be carried out by authorized personnel, for a fee and on the basis of a defined tariff, for interventions, based on the tables issued by the Civil Engineers and, for spare parts based on the latest revision. of the internal VDS price lists.

ARTICLE 7: LEGAL COURT

In case of disputes, the legal court is established in Pescara.

VDS IS NOT RESPONSIBLE IN CASE OF BAD WEATHER CONDITION ACCIDENTS AND ANY ACCIDENTAL ACTION OR VANDALS ACCIDENTS. ALL INFORMATION REPORTED, ARE SIMPLY INDICATIVES. VDS RESERVES ITS RIGHTS TO MODIFY PRODUCTS WITHOUT FURTHER COMMUNICATION. THE PRESENT PRICE LIST CANCELS AND SUBSTITUES THE PREVIOUS.



ITALIA
VDS AUTOMAZIONI SRL

Via Circolare P.I.P. 10
65010 Spoltore (PE) - Italia
Tel: +39 085 497 1946
Fax: +39 085 497 3849
info@vdsautomation.com
www.vdsautomation.com

SPAGNA
VDS AUTOMATISMOS IBERICA

Calle Sierra Carbonera, 24
28500 Arganda del Rey, Madrid - Spain
Tel: +34 918 706 760
Fax: +34 618 356 558
info@vdsautomatismos.es